

# SPEED BUMP - SBD-72

APPROX WEIGHT: 45.05 lbs.  
 DOES NOT INCLUDE WEIGHT OF POWER OR PACKAGING!!!

\*\*\* ANY ADDITIONS, DELETIONS, OR OMISSIONS MUST BE CORRECTED ON THIS DRAWING AS THIS DRAWING WILL BE CONSIDERED ALL INCLUSIVE \*\*\*

ALL GRAPHICS PROVIDED ARE FOR REFERENCE ONLY. IF CERTAIN DIMENSIONS ARE CRITICAL PLEASE VERIFY THOSE DIMENSIONS WITH YOUR SALESPERSON

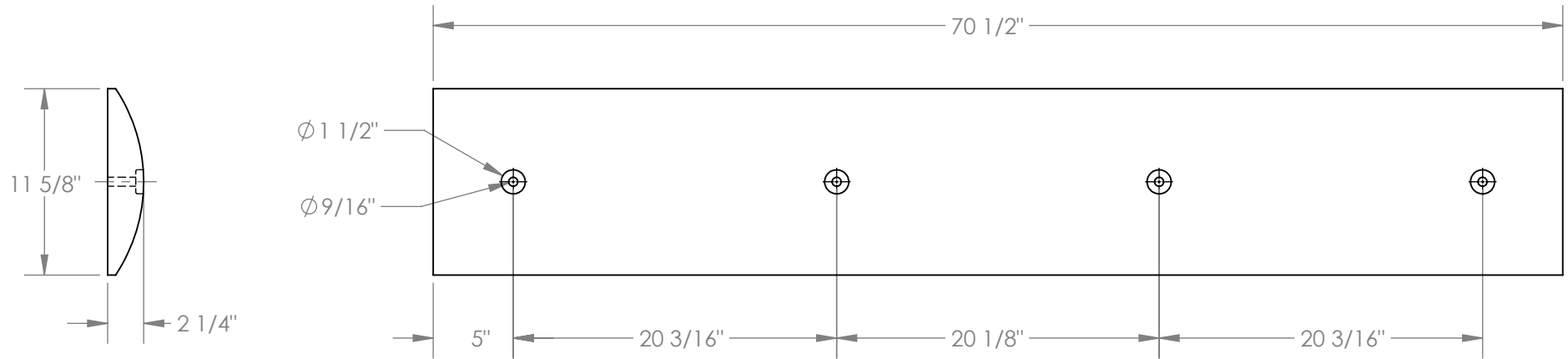

DIMENSION TOLERANCE  $\pm 1/4$ "

## STANDARD FEATURES

MODEL NUMBER IS SBD-72  
 OVERALL WIDTH IS 11 5/8"  
 OVERALL LENGTH IS 70 1/2"  
 OVERALL HEIGHT IS 2 1/4"  
 MAX CAPACITY IS 3,200 PSI  
 CONCRETE HARDWARE KIT INCLUDED

## SPECIAL FEATURES

NONE

**APPROVAL**

I, THE UNDERSIGNED, AGREE THAT THE PRODUCT AS REPRESENTED SATISFIES DESIGN AND DIMENSION REQUIREMENTS. I ALSO ACKNOWLEDGE MY DUTY TO CONFIRM PRODUCT AND INSTALLATION COMPLIANCE WITH ALL APPLICABLE FEDERAL, STATE AND LOCAL REGULATIONS AND STANDARDS.  
**ALL SPECIAL UNITS ARE NON-RETURNABLE**  
 As drawn       As marked

Signed: \_\_\_\_\_ Date: \_\_\_\_\_

LEAD TIME WILL START UPON RECEIPT OF SIGNED APPROVAL DRAWING

FOR INTERNAL USE ONLY PROJECT SIGN OFF	
SALES	
ENG.	
FAB.	
POWER	

DISTRIBUTOR'S NAME:		P.O.#
VESTIL MANUFACTURING		X
DRAWN BY: K.YEAKLE		DATE: 06/15/12
REFERENCE: X		SCALE: 1:10
QUOTED LEAD TIME: X		QUOTE # X
		W.O.# X
		SALES: X
		FILE NAME: 29-007-182