



Est. 1954

ACORN ENGINEERING COMPANY
Manufacturers of Engineered Plumbing Products

ACORN WATER COOLERS & DRINKING FOUNTAINS

Option BF2 Series Sensor Operated Bottle Filler

SUGGESTED SPECIFICATIONS

Model BF2 is a 9 volt sensor operated bottle filler designed to be used with an Acorn A171 or A111 Series Barrier-Free Water Cooler. When installed properly, the bottle filler complies with ADA forward reach requirements. Cabinet shall be Granite powder coated on galvanized or stainless steel. Certified to meet NSF/ANSI 61.9, CHSC 116875, and National Reduction of Lead in Drinking Water S.3874.



Model BF2S-BCD Shown

STANDARD FEATURES

- 115v Plug-in Transformer
- 100 mesh inlet strainer
- Laminar Flow Water Supply
- Hands Free Sensor Operation
- 1 G.P.M. Fill Rate
- 100% Lead & Brass Free



Member of
U.S. Green
Building
Council



Recyclable
Product



Water
Conserving
Product

CONFIGURING SPECIFIC MODEL NO. & OPTIONS

Model (Must Specify)

- BF2 Granite Powder Coat Galvanized Steel (Std)
- BF2S 18 Gage 304 Stainless Steel
- BF2-BCD Granite Powder Coat Galvanized Steel (Std) w/Bottle Counter Display
- BF2S-BCD 18 Gage 304 Stainless Steel w/Bottle Counter Display

OPTIONAL ACCESSORIES :

- BAT Battery Operated (N/A With Bottle Counter)
- WF1 1500 Gallon Capacity, Nsf 42+53, 1 Micron Lead Reduction Filter (Filter Installed In Host Cooler)

Acorn Engineering Company™ assumes no responsibility for use of void or superseded data. © Copyright Acorn Engineering, City of Industry, CA Member of Morris Group International. Please visit www.acorneng.com for most current specifications.

AO.BF2

Date: 07/24/13

COMPLIES WITH STANDARDS



Test rating conditions are compliant with ARI 1010.

ACORN ENGINEERING COMPANY
Est. 1954
Manufacturers of Engineered Plumbing Products

Member of MORRIS GROUP INTERNATIONAL

ACORN ENGINEERING COMPANY
15125 Proctor Ave.
City of Industry, CA
91746 U.S.A.
Phone 800-591-9360
626-336-4561
Fax 626-855-4894
www.acorneng.com



TECHNICAL DIMENSIONS

All dimensions are subject to manufactures tolerance of plus or minus 1/2" nominal and subject to change without notice. Acorn Engineering assumes no responsibility for use of void or superseded data. Dimensions may change with the addition of optional accessories. Acorn Engineering Company™, Member of Morris Group International™. Please visit www.acorneng.com for most current specifications.

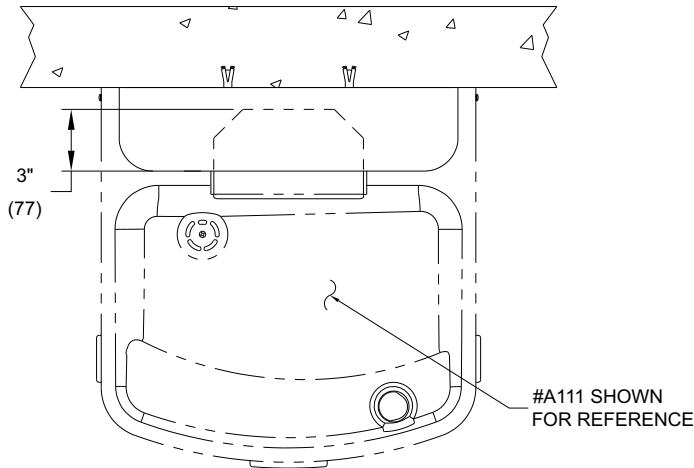

TOP VIEW

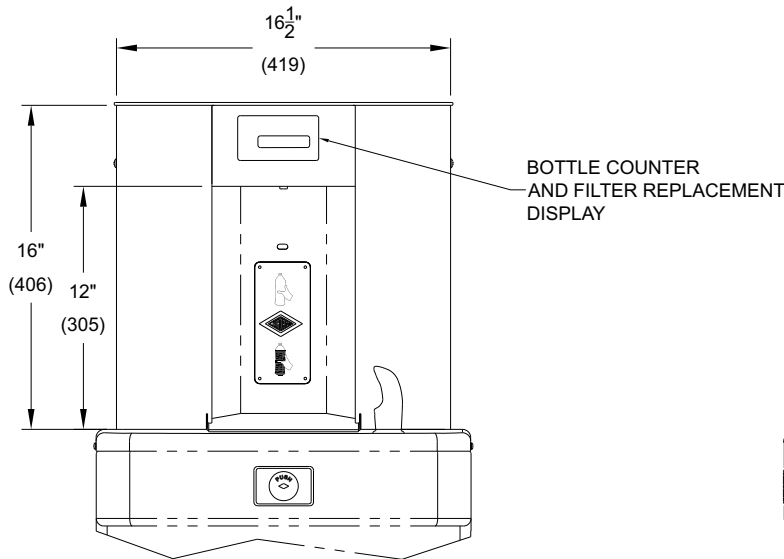

FRONT VIEW

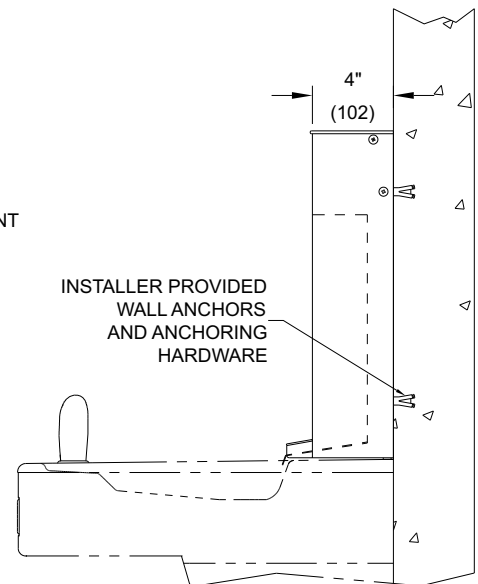

SIDE VIEW

GENERAL NOTES:
1. ALL DIMENSIONS ARE IN INCHES (MM).

A0.BF2 Date: 07/24/13

Acorn Engineering Company™ warrants that its products are free from defects in material or workmanship under normal use and service for a period of one year from date of shipment. Acorn's™ liability under this warranty shall be discharged solely by replacement or repair of defective material, provided Acorn™ is notified in writing within one year from date of shipment, F.O.B. Industry, California.

SELECTION SUMMARY & APPROVAL FOR MANUFACTURING

Model Number & Options _____ Quantity _____

Company _____

Contact _____ Title _____

Signature (Approval for Manufacturing) _____ Date _____

ACORN
WATER COOLERS & DRINKING FOUNTAINS
800-591-9360
626-336-4561
www.acorneng.com