

# HAND TRUCK PANEL CART, HT-PANEL

APPROXIMATE WEIGHT IS: 67.36 lbs.

\*\*\* ANY ADDITIONS, DELETIONS, OR OMISSIONS MUST BE CORRECTED ON THIS DRAWING AS THIS DRAWING WILL BE CONSIDERED ALL INCLUSIVE \*\*\*

ALL GRAPHICS PROVIDED ARE FOR REFERENCE ONLY. IF CERTAIN DIMENSIONS ARE CRITICAL PLEASE VERIFY THOSE DIMENSIONS WITH YOUR SALESPERSON

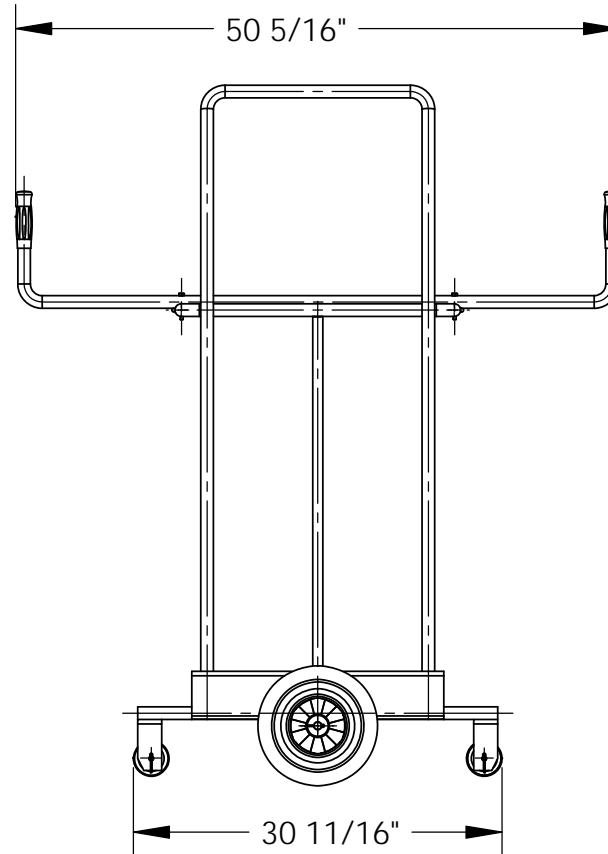
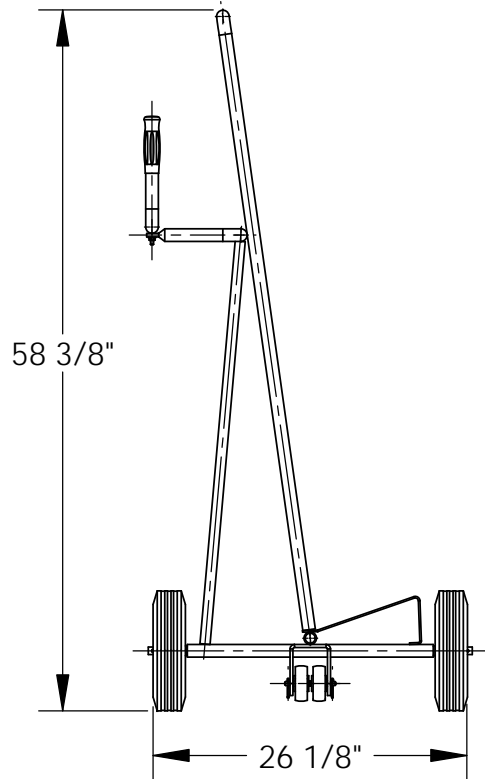

## STANDARD FEATURES

MODEL NUMBER IS HT-PANEL  
 CAPACITY IS 750 LBS.  
 OVERALL WIDTH IS 26 1/8"  
 OVERALL LENGTH IS 50 5/16"  
 OVERALL HEIGHT IS 58 3/8"  
 TWO SEMI-PNEUMATIC 10" CASTERS  
 FOUR RIGID 3" CASTERS

**ALL SPECIAL UNITS  
 ARE NON-RETURNABLE**

<b>A P P R O V A L</b>	I, the undersigned, hereby approve this print. This includes my approval of design & dimensions	
	<input type="checkbox"/> As drawn	<input type="checkbox"/> As marked
	Signed: _____ Date: _____	
<b>LEAD TIME WILL START UPON RECEIPT OF SIGNED APPROVAL DRAWING</b>		

DISTRIBUTOR'S NAME: <b>VESTIL MANUFACTURING</b>		P.O.# X
DRAWN BY: JDB	DATE: 6/23/08	W.O.# X
REFERENCE: X	QUOTE # X	SALES: X
		FILE NAME: 33-007-101
		SCALE: 1:16