

# MANUAL ADJUSTABLE ERGONOMIC WORK BENCH - EWB-7236

APPROX WEIGHT: 339 lbs.  
DOES NOT INCLUDE WEIGHT OF POWER OR PACKAGING!!!

\*\*\* ANY ADDITIONS, DELETIONS, OR OMISSIONS MUST BE CORRECTED ON THIS DRAWING AS THIS DRAWING WILL BE CONSIDERED ALL INCLUSIVE \*\*\*  
ALL GRAPHICS PROVIDED ARE FOR REFERENCE ONLY. IF CERTAIN DIMENSIONS ARE CRITICAL PLEASE VERIFY THOSE DIMENSIONS WITH YOUR SALESPERSON

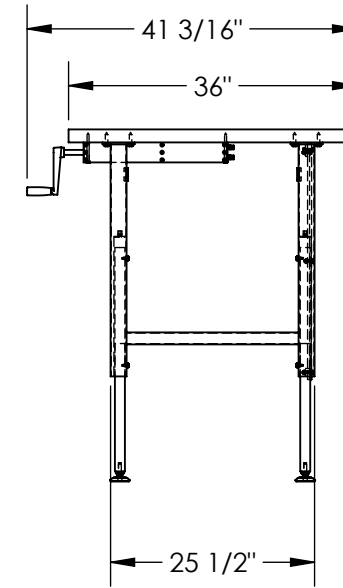
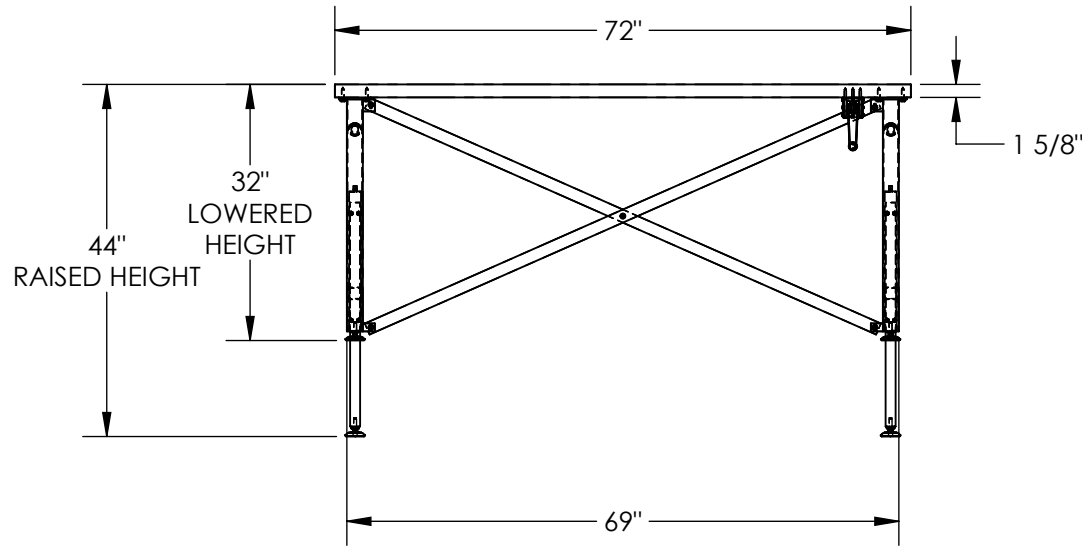

## STANDARD FEATURES

MODEL NUMBER IS EWB-7236  
OVERALL WIDTH IS 41 3/16"  
USABLE WIDTH IS 36"  
OVERALL LENGTH IS 72"  
USABLE LENGTH IS 72"  
MAX RAISED HEIGHT IS 44"  
MAX LOWERED HEIGHT IS 32"  
MAX UNIFORM CAPACITY IS 750 LBS  
FOLD AWAY CRANK HANDLE FOR MANUAL OPERATION  
HYDRAULIC SYSTEM RAISES PLATFORM EVENLY  
PLATFORM IS A MAPLE BENCH TOP W/ CATALYZED LACQUER FINISH  
180° BULL NOSE ON 72" SIDE OF PLATFORM  
UNDERSTRUCTURE IS MADE OF STEEL

## SPECIAL FEATURES

NONE

DIMENSION TOLERANCE  $\pm 1/4"$

APPROVAL

I, THE UNDERSIGNED, AGREE THAT THE PRODUCT AS REPRESENTED SATISFIES DESIGN AND DIMENSION REQUIREMENTS. I ALSO ACKNOWLEDGE MY DUTY TO CONFIRM PRODUCT AND INSTALLATION COMPLIANCE WITH ALL APPLICABLE FEDERAL, STATE AND LOCAL REGULATIONS AND STANDARDS.  
**ALL SPECIAL UNITS ARE NON-RETURNABLE**  
[ ] As drawn [ ] As marked

Signed: \_\_\_\_\_ Date: \_\_\_\_\_

LEAD TIME WILL START UPON RECEIPT OF SIGNED APPROVAL DRAWING

DISTRIBUTOR'S NAME:		P.O.#
VESTIL MANUFACTURING		X
DRAWN BY: DEY		W.O.#
DATE: 9/5/12		X
REFERENCE: X	SCALE: 1:24	SALES: X
QUOTED LEAD TIME: X	QUOTE # X	FILE NAME:
		43-007-002