

MANUAL ADJUSTABLE ERGONOMIC WORK BENCH - EWB-6030

APPROX WEIGHT: 316 lbs.
DOES NOT INCLUDE WEIGHT OF POWER OR PACKAGING!!!

*** ANY ADDITIONS, DELETIONS, OR OMISSIONS MUST BE CORRECTED ON THIS DRAWING AS THIS DRAWING WILL BE CONSIDERED ALL INCLUSIVE ***
ALL GRAPHICS PROVIDED ARE FOR REFERENCE ONLY. IF CERTAIN DIMENSIONS ARE CRITICAL PLEASE VERIFY THOSE DIMENSIONS WITH YOUR SALESPERSON

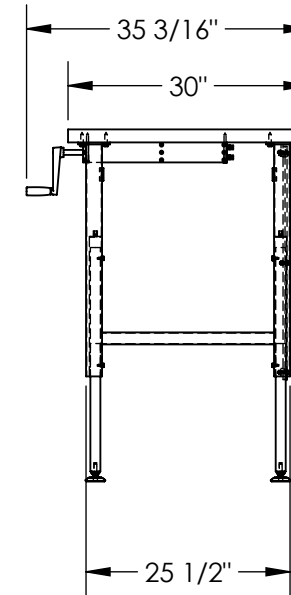
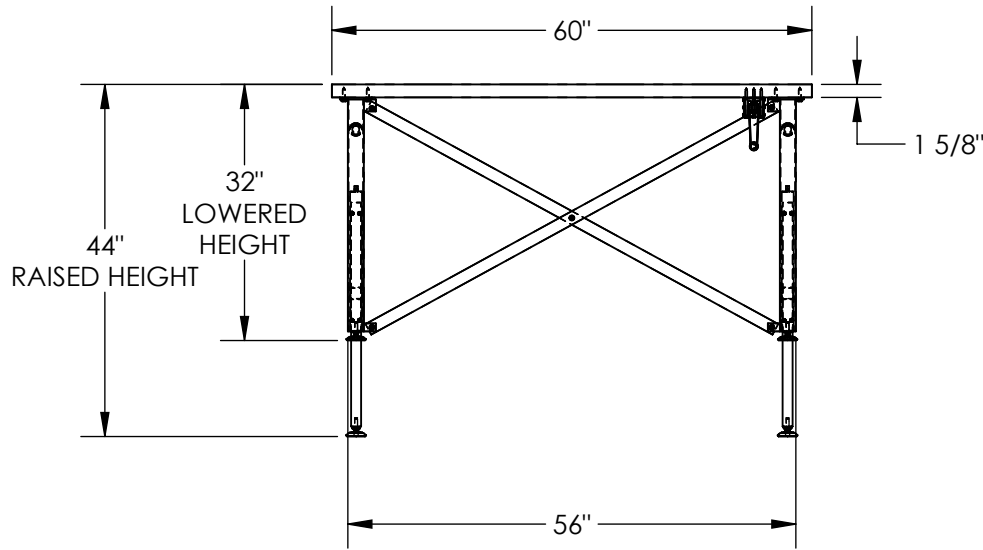

STANDARD FEATURES

MODEL NUMBER IS EWB-6030
OVERALL WIDTH IS 35 3/16"
USABLE WIDTH IS 30"
OVERALL LENGTH IS 60"
USABLE LENGTH IS 60"
MAX RAISED HEIGHT IS 44"
MAX LOWERED HEIGHT IS 32"
MAX UNIFORM CAPACITY IS 750 LBS
FOLD AWAY CRANK HANDLE FOR MANUAL OPERATION
HYDRAULIC SYSTEM RAISES PLATFORM EVENLY
PLATFORM IS A MAPLE BENCH TOP W/ CATALYZED LACQUER FINISH
UNDERSTRUCTURE IS MADE OF STEEL

SPECIAL FEATURES

NONE

DIMENSION TOLERANCE $\pm 1/4"$

APPROVAL

I, THE UNDERSIGNED, AGREE THAT THE PRODUCT AS REPRESENTED SATISFIES DESIGN AND DIMENSION REQUIREMENTS. I ALSO ACKNOWLEDGE MY DUTY TO CONFIRM PRODUCT AND INSTALLATION COMPLIANCE WITH ALL APPLICABLE FEDERAL, STATE AND LOCAL REGULATIONS AND STANDARDS.
ALL SPECIAL UNITS ARE NON-RETURNABLE
[] As drawn [] As marked

Signed: _____ Date: _____

LEAD TIME WILL START UPON RECEIPT OF SIGNED APPROVAL DRAWING

DISTRIBUTOR'S NAME:		P.O.#
VESTIL MANUFACTURING		X
DRAWN BY: DEY		W.O.#
DATE: 9/5/12		X
REFERENCE: X	SCALE: 1:24	SALES: X
QUOTED LEAD TIME: X	QUOTE # X	FILE NAME:
		43-007-001