



**VESTIL MANUFACTURING CORP.**  
 2999 North Wayne Street, P.O. Box 507, Angola, IN 46703  
 Telephone: (260) 665-7586 -or- Toll Free (800) 348-0868  
 Fax: (260) 665-1339  
 www.vestilmfg.com e-mail: [sales@vestil.com](mailto:sales@vestil.com)

## JIB-FM Series Floor Mounted Jib Cranes Instruction Manual



### RECEIVING INSTRUCTIONS:

After delivery, IMMEDIATELY remove the packaging from the product. Inspect the product closely to determine whether it sustained damage during transport. If damage is discovered, record a complete description of it on the bill of lading and notify the freight carrier. If the product is undamaged, discard the packaging.

### NOTICES:

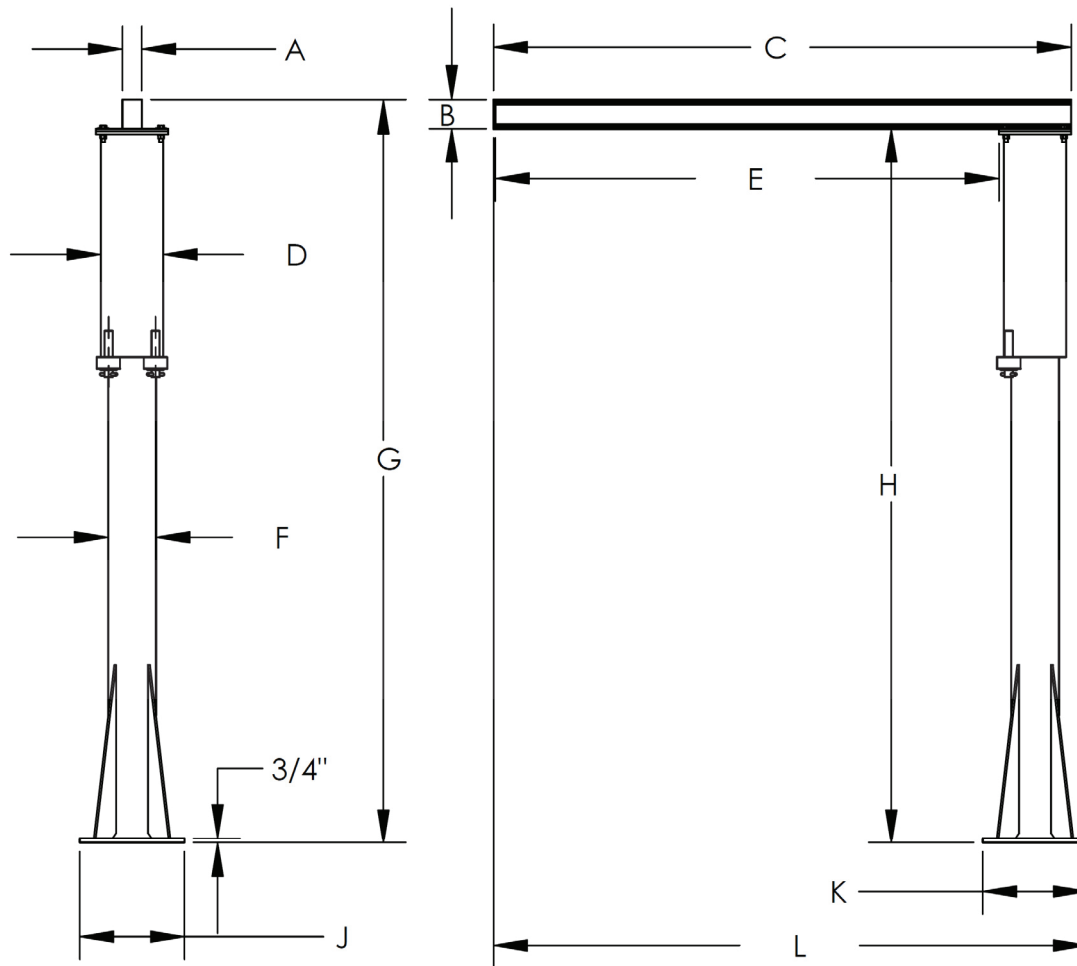
- 1) Compliance with laws, regulations, codes, and non-voluntary standards enforced in the location where the product is *used* is the responsibility of the end-user.
- 2) VESTIL is not liable for any injury or property damage resulting from failure to apply either:
  - a) Instructions in this manual; or
  - b) Information provided on labels attached to the product.
- 3) Vestil is not responsible for consequential damages sustained while assembling, using, or maintaining this product.

### **Table of Contents**

Jib specifications.....	2
Signal words.....	2
Safe use recommendations.....	3
FIGS. 1-5: Exploded parts diagrams and bills of materials.....	3 - 5
Assembly instructions.....	6 - 7
Function tests.....	8
Use instructions.....	8 - 9
Inspections.....	9
Maintenance.....	10
Labeling diagram.....	10
Limited warranty.....	11

## Jib Specifications:

Crane dimensions and net weight appear in the table below.



Model	A	B	C	D	E	F	G	H	J	K	L	Capacity	Net wt.
JIB-FM-3	2 <sup>11</sup> / <sub>16</sub> "	4"	80"	8 <sup>5</sup> / <sub>8</sub> "	69 <sup>3</sup> / <sub>4</sub> "	6 <sup>5</sup> / <sub>8</sub> "	103 <sup>1</sup> / <sub>4</sub> "	99 <sup>1</sup> / <sub>4</sub> "	14 <sup>1</sup> / <sub>2</sub> "	14 <sup>1</sup> / <sub>2</sub> "	82 <sup>1</sup> / <sub>4</sub> "	300 lb.	382 lb.
JIB-FM-6	4"	6"	80"	8 <sup>5</sup> / <sub>8</sub> "	69 <sup>3</sup> / <sub>4</sub> "	6 <sup>5</sup> / <sub>8</sub> "	105 <sup>1</sup> / <sub>4</sub> "	99 <sup>1</sup> / <sub>4</sub> "	14 <sup>1</sup> / <sub>2</sub> "	14 <sup>1</sup> / <sub>2</sub> "	82 <sup>1</sup> / <sub>4</sub> "	600 lb.	412 lb.
JIB-FM-10	4"	6"	80"	10 <sup>3</sup> / <sub>4</sub> "	67 <sup>3</sup> / <sub>4</sub> "	8 <sup>5</sup> / <sub>8</sub> "	105 <sup>1</sup> / <sub>2</sub> "	99 <sup>1</sup> / <sub>2</sub> "	17"	17"	82 <sup>1</sup> / <sub>4</sub> "	1,000 lb.	563 lb.
JIB-FM-20	4"	10 <sup>1</sup> / <sub>8</sub> "	80"	10 <sup>3</sup> / <sub>4</sub> "	67 <sup>3</sup> / <sub>4</sub> "	8 <sup>5</sup> / <sub>8</sub> "	109 <sup>5</sup> / <sub>8</sub> "	99 <sup>1</sup> / <sub>2</sub> "	17"	17"	82 <sup>1</sup> / <sub>4</sub> "	2,000 lb.	596 lb.
JIB-FM-40	6 <sup>1</sup> / <sub>2</sub> "	12 <sup>1</sup> / <sub>4</sub> "	80 <sup>3</sup> / <sub>8</sub> "	12"	66 <sup>1</sup> / <sub>8</sub> "	10 <sup>3</sup> / <sub>4</sub> "	111 <sup>1</sup> / <sub>2</sub> "	99 <sup>1</sup> / <sub>2</sub> "	24"	24"	83 <sup>7</sup> / <sub>8</sub> "	4,000 lb.	765 lb.

## Signal Words:

This manual uses SIGNAL WORDS to call attention to uses of this product that are likely to result in personal injuries or property damage. The signal words used in this manual appear below along with their definitions.



**DANGER**

Identifies a hazardous situation which, if not avoided, WILL result in DEATH or SERIOUS INJURY. Use of this signal word is limited to the most extreme situations.



**WARNING**

Identifies a hazardous situation which, if not avoided, COULD result in DEATH or SERIOUS INJURY.



**CAUTION**

Indicates a hazardous situation which, if not avoided, COULD result in MINOR or MODERATE injury.



**NOTICE**

Identifies practices likely to result in product/property damage, such as operation that might damage the product or other property.

## Safe Use Recommendations:

Study the entire manual before using this crane. We recommend that a copy of the manual be stored on/attached to the crane at all times. Read the manual to refresh your understanding of the safe operation, inspection or maintenance procedures whenever necessary.

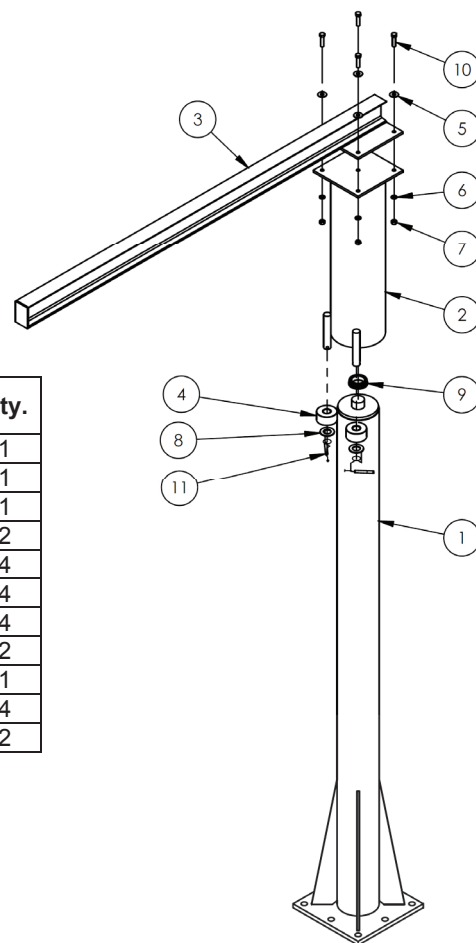
**⚠ DANGER** DO not install or use the crane in areas where it will contact electrified wires. Electrocutation might occur if the crane, hoist, or load, etc. contacts electrified wires.

**⚠ WARNING** Improper or careless operation might result in serious personal injuries.

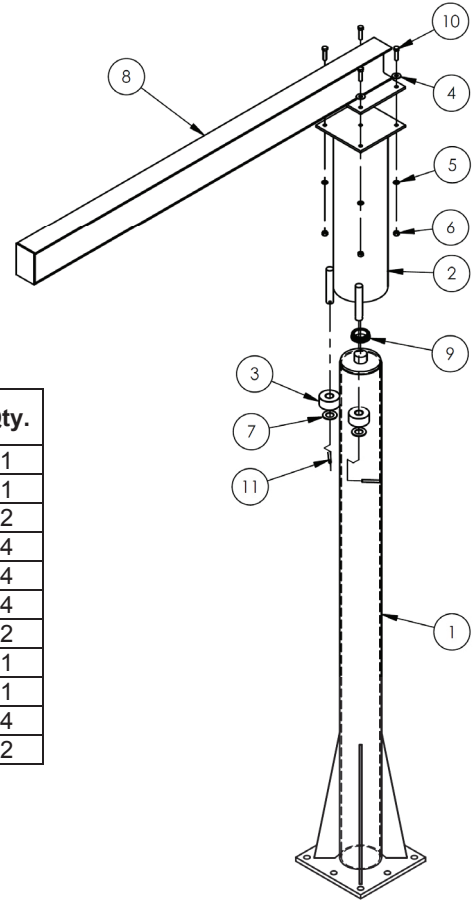
- ALWAYS apply operation, inspection, and maintenance recommendations in 29 CFR 1910.179. Contact the occupational safety and health institution of the state where the crane is used for requirements applied to jib cranes.
- DO NOT use a damaged or malfunctioning jib! Restore the crane to normal operating condition before returning it to service.
- DO NOT exceed the capacity of your jib (see “Jib specifications” table on p. 2). The weights of the load, hoist, trolley, rigging, and all other equipment attached to the jib must be added together to determine the net weight applied to the jib. The net weight must never exceed the capacity.
- Always perform the “Function Tests” (p. 8) before each use.
- Inform all persons in the area that you are going to use the crane. Instruct them to stay out of the area during operation.
- NO ONE should ever stand beneath or travel under the crane when a load is suspended from it.
- DO NOT use the jib to lift/support people.
- ALWAYS load the jib as recommended on p. 8. Failure to properly position a load might cause the load to swing when it is lifted. Load swing might result in serious injury.
- DO NOT use the crane if any label is unreadable, damaged, or missing (see “Labeling diagram” on p. 10). Contact Vestil for replacement labels.
- DO NOT modify the crane! Modifications automatically void the limited warranty (see p. 11) and might make the crane unsafe to use.

**FIG. 1:** JIB-FM-3 Exploded Parts Diagram and Bill of Materials

Item No.	Part No.	Description	Qty.
1	28-514-050	Weldment, floor mount subassembly (“Mast”)	1
2	28-514-044	Weldment, pivot subassembly (“Socket”)	1
3	28-514-048	Weldment, I-beam subassembly (“Boom”)	1
4	05-527-300	Roller, assembly	2
5	33012	Flat washer, low carbon, zinc finish, $\frac{1}{2}$ ”	4
6	33626	Lock washer, zinc plated, $\frac{1}{2}$ ”	4
7	36310	$\frac{1}{2}$ ”-13 UNC grade 5, hex nut, zinc plated	4
8	33098	$1\frac{1}{8}$ ” SAE flat washer, zinc-plated	2
9	28-110-001-001	Inner bearing	1
10	13211	$\frac{1}{2}$ ” -13x2” HHCS #5, zinc plated bolt	4
11	64319	Pin, spring, $\frac{3}{8}$ ” x 3”	2

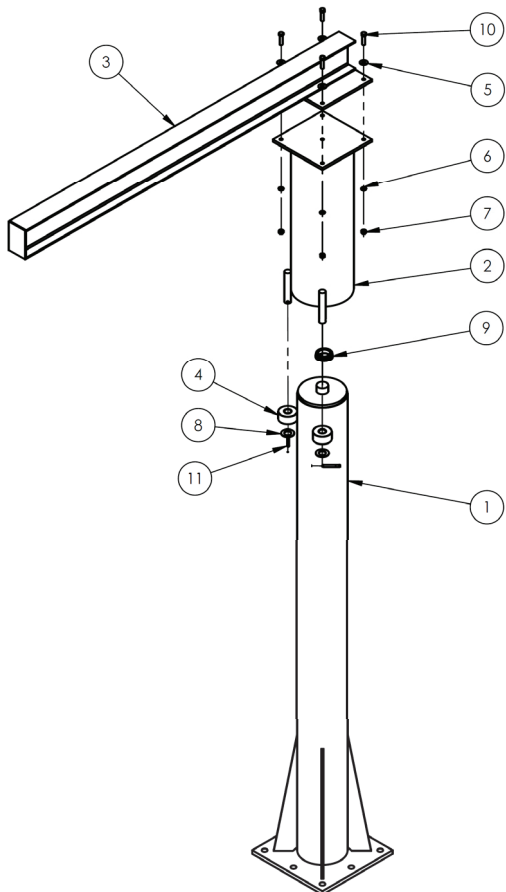


**FIG. 2: JIB-FM-6 Exploded Parts Diagram and Bill of Materials**



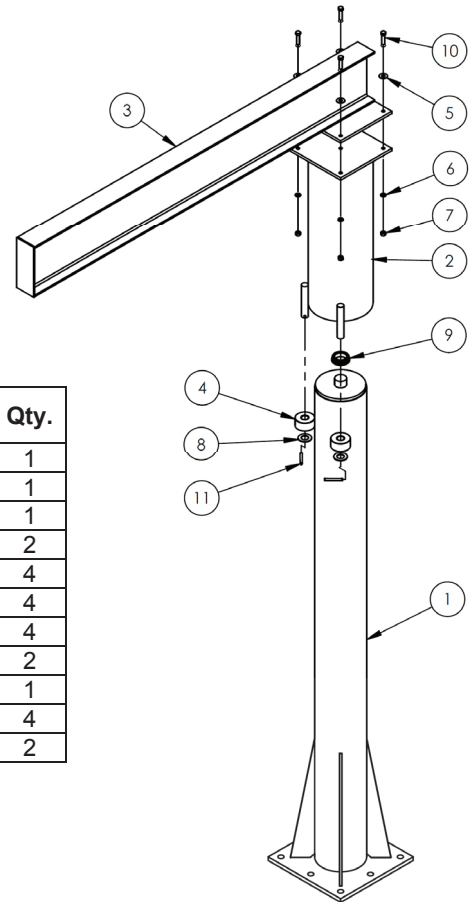
Item No.	Part No.	Description	Qty.
1	28-514-050	Weldment, floor mount subassembly ("Mast")	1
2	28-514-044	Weldment, pivot subassembly ("Socket")	1
3	05-527-300	Roller, assembly	2
4	33012	Flat washer, low carbon, zinc finish, 1/2"	4
5	33626	Lock washer, zinc plated, 1/2"	4
6	36310	1/2"-13 UNC grade 5, hex nut, zinc plated	4
7	33098	1 1/8" SAE flat washer, zinc-plated	2
8	28-514-049	Weldment, I-beam subassembly ("Boom")	1
9	28-110-001-001	Inner bearing	1
10	13211	1/2" -13x2" HHCS #5, zinc plated bolt	4
11	64319	Pin, spring, 3/8" x 3"	2

**FIG. 3: JIB-FM-10 Exploded Parts Diagram and Bill of Materials**



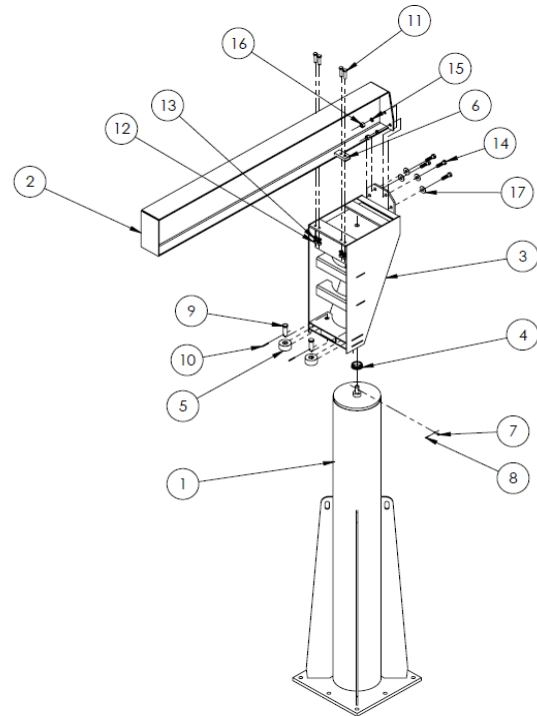
Item No.	Part No.	Description	Qty.
1	28-514-047	Weldment, floor mount subassembly ("Mast")	1
2	28-514-045	Weldment, pivot subassembly ("Socket")	1
3	28-514-166	Weldment, I-beam subassembly ("Boom")	1
4	05-527-300	Roller, assembly	2
5	33012	Flat washer, low carbon, zinc finish, 1/2"	4
6	33626	Lock washer, zinc plated, 1/2"	4
7	36310	1/2"-13 UNC grade 5, hex nut, zinc plated	4
8	33098	1 1/8" SAE flat washer, zinc-plated	2
9	28-110-001-001	Inner bearing	1
10	13211	1/2" -13x2" HHCS #5, zinc plated bolt	4
11	64319	Pin, spring, 3/8" x 3"	2

**FIG. 4: JIB-FM-20 Exploded Parts Diagram and Bill of Materials**



Item No.	Part No.	Description	Qty.
1	28-514-047	Weldment, floor mount subassembly ("Mast")	1
2	28-514-045	Weldment, pivot subassembly ("Socket")	1
3	28-514-046	Weldment, I-beam subassembly ("Boom")	1
4	05-527-300	Roller, assembly	2
5	33012	Flat washer, low carbon, zinc finish, 1/2"	4
6	33626	Lock washer, zinc plated, 1/2"	4
7	36310	1/2"-13 UNC grade 5, hex nut, zinc plated	4
8	33098	1 1/8" SAE flat washer, zinc-plated	2
9	28-110-001-001	Inner bearing	1
10	13211	1/2" -13x2" HHCS #5, zinc plated bolt	4
11	64319	Pin, spring, 3/8" x 3"	2

**FIG. 5: JIB-FM-40 Exploded Parts Diagram and Bill of Materials**



Item No.	Part No.	Description	Qty.
1	28-514-299	Weldment, Pivot Pipe	1
2	28-514-301	Weldment, Frame, Beam	1
3	28-514-300	Weldment, Frame, Upper	1
4	28-110-001-001	Inner Bearing	1
5	05-527-300	Roller Assembly	2
6	28-516-081	Weldment, Bracket, Beam Clamp	2
7	28-112-049	Pin, Clevis, 3/8" dia.	1
8	65077	Cotter Pin, Zinc Plated, 1/8" x 1-1/14"	1
9	28-112-050	Pin, Clevis, 1 1/8" dia	2
10	64255	0.25 x 2 LG Spring Pin	2
11	12313	Hex Bolt, Grade 5, Plain Finish, 5/8"-11 x 2 1/2"	4
12	36114	Hex Nut Z-Plated, 5/8 - 11 UNC	4
13	33630	5/8" Zinc Finish Medium Split Lock Washer	4
14	13363	3/4-10 x 2 1/2 HHCS #5 Z Plated	4
15	33632	3/4 Lock Washer	4
16	36116	3/4-10 Hex Nut	4
17	33018	USS Flat Washer, Z Plated, 3/4"	4

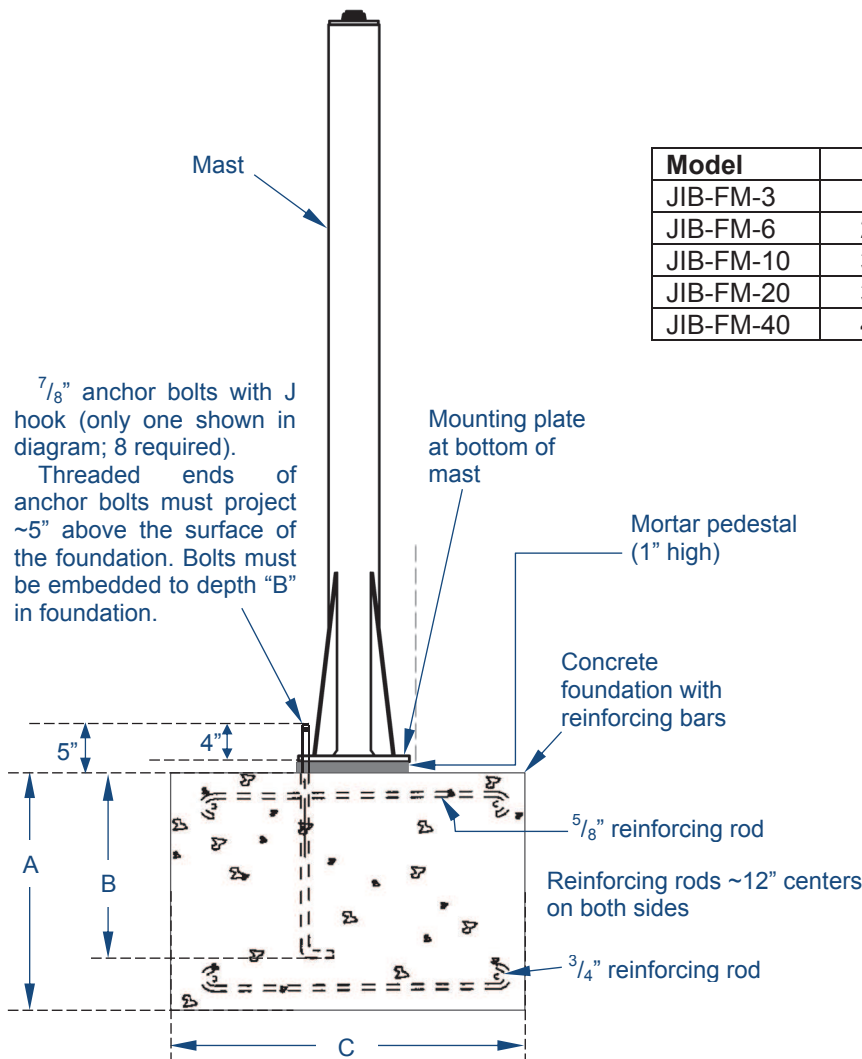
**Assembly Instructions:**

Numbers in parentheses correspond to parts numbers in the exploded parts diagrams on pp. 3-5.

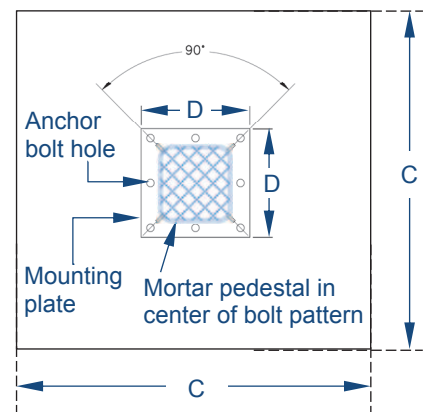
**Step 1:** Create a foundation for the jib. The necessary minimum foundation requirements for each JIB-FM model crane are provided in the diagrams and table below. When the foundation is adequately cured, install eight (8)  $\frac{7}{8}$ " jam nuts on the anchor bolts. Wind them to the surface of the foundation. Level across the jam nuts by raising/lowering specific nuts as necessary to make all of the nuts level. Then, fill the center of the bolt pattern (see "Overhead View of Foundation" diagram below) with grout, e.g. Morta Mix. The top of the grout pedestal should be level with the tops of the jam nuts.

**Step 2:** Set the mast on the foundation. Align the bolt holes in the mounting plate with the anchor bolts and carefully lower the mast onto the leveling nuts. Install  $\frac{7}{8}$ " lock nuts on the anchor bolts but leave them loose. Plumb the mast at 90° increments, i.e. check the vertical levelness of the mast at 4 locations equally spaced around the circumference of the mast. Adjust the leveling nuts as necessary to fine tune mast levelness; then tighten the lock nuts against the mounting plate.

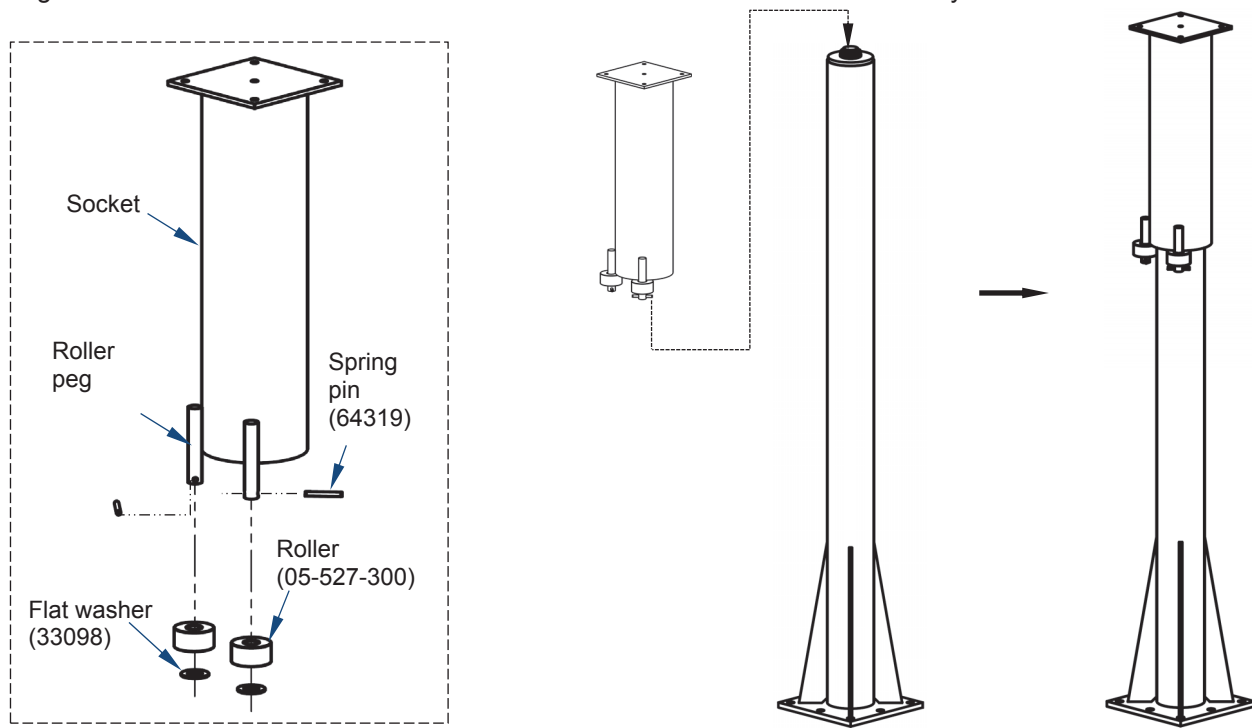
Model	A	B	C	D
JIB-FM-3	18"	15"	42"	14 $\frac{1}{2}$ "
JIB-FM-6	24"	19"	46"	14 $\frac{1}{2}$ "
JIB-FM-10	30"	23"	50"	17"
JIB-FM-20	30"	23"	60"	17"
JIB-FM-40	48"	41"	72"	24"



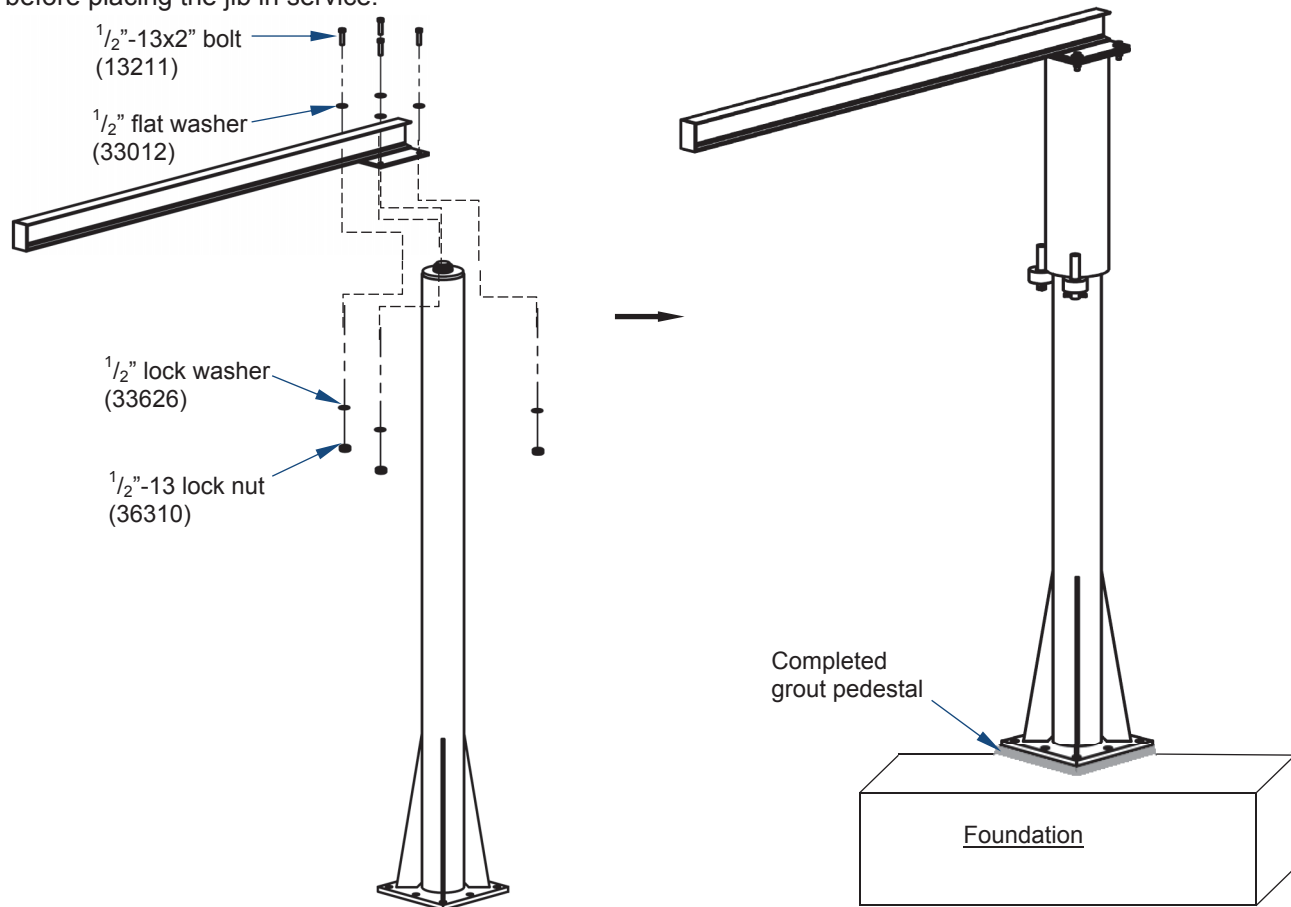
**Overhead View of Foundation**



**Step 3:** Install the roller assemblies on the roller pegs as shown below. Liberally grease the thrust bearing inside the socket. Then, install the socket over the top of the mast. Make sure that the seats within the thrust bearing by rotating the socket clockwise and counterclockwise. The socket should turn smoothly in both directions.



**Step 4:** Attach the boom to the socket using  $\frac{1}{2}$ " hardware as indicated in the diagrams below. Fasten bolts and lock nuts to 94ft.-lb. of torque. Fill the remaining space under the mounting plate with grout. Allow the grout to fully cure before placing the jib in service.



## Function Tests:

Verify that the jib operates normally by performing the tests below. If an issue is discovered, tag the crane "Out of Service". Restore the crane to normal operating condition before returning it to service.

1. Test the bearing: rotate the boom in both directions. Make sure that the boom rotates smoothly. Listen for unusual noises while the boom rotates. If the boom wobbles or is unusually noisy, remove the boom and socket from the mast. Grease the bearing inside the socket. Reinstall the boom and socket on top of the mast. If lubrication does not resolve the problem, the bearing might need to be replaced. Contact the factory to discuss the problem and to order replacement parts.
2. Test the hoist and trolley according to the manufacturers' instructions.

## Use instructions:

Before using the crane for the first time, perform an "Initial Inspection" as described in 29 CFR 1910.179. The inspection procedure is paraphrased on p. 9. However, you should read the entire regulation periodically. The regulation is published on <http://www.OSHA.gov> as standard 1910.179 for "General Industry".

### **WARNING**

To reduce the likelihood of serious personal injuries caused by improper or careless operation:

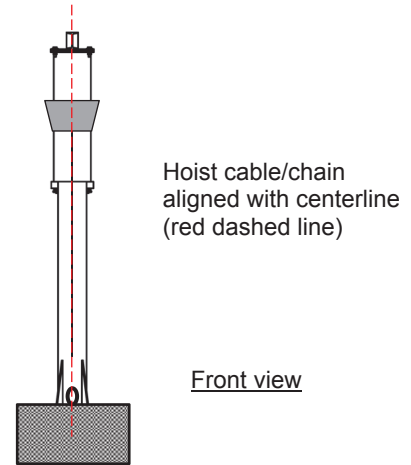
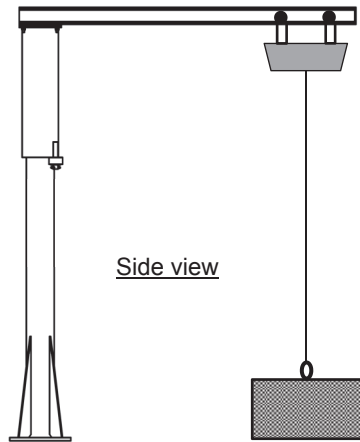
- Only qualified, designated crane operators should use this device. The operating instructions in this manual *supplement* safe (crane and hoist) operation techniques learned during your training program. ALWAYS apply those techniques and conform to OSHA crane operation standards (29 CFR 1910.179).
- Instruct all persons to remain at a safe distance during operation. All personnel not using the crane should remain outside the operating area during use.
- Tag the crane "Out of service" and notify your maintenance personnel if: 1) you observe any damage to the anchor bolts or the foundation especially the concrete around the anchor bolts; 2) hear unusual noise during use; 3) see warps, cracks, etc. of the boom, the mounting plate (base of the mast), the socket, or the load hook or chain/cable.

### Proper load lifting:

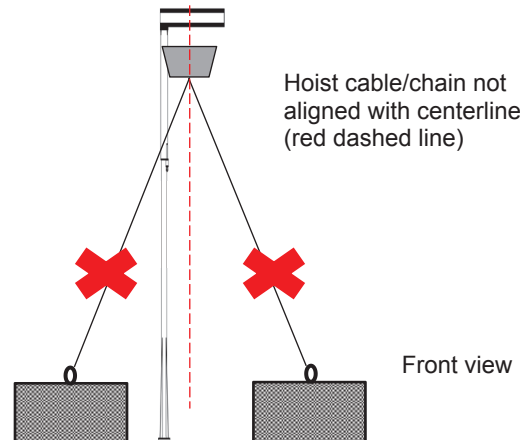
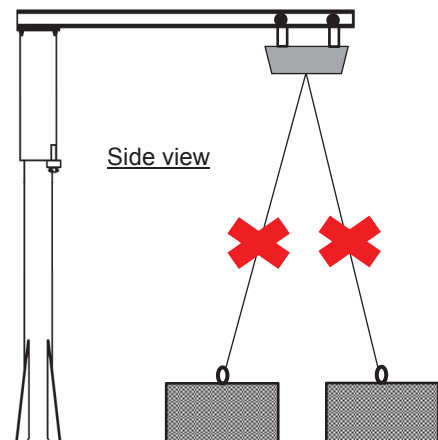
Always follow the instructions provided with your hoist and trolley.

Position the trolley and hoist directly above the load. Proper positioning is diagrammed below:

### Proper load centering beneath hoist and trolley



### Improperly positioned loads





Connect the load to the hoist chain/cable, using appropriate rigging. Then, raise the load only as high as necessary. To rotate the boom, slowly direct the load to the desired location. Once the boom and hoist are properly centered above the work location, lower the load and disconnect it from the hoist.

## Inspections:

Apply Occupational Safety and Health Administration (OSHA) crane inspection procedures in 29 CFR 1910.179). Inspections are classified according to the intervals at which inspection should be performed.

1. **Initial inspection** — before a new or modified crane may be used for the first time, it must be inspected to insure normal condition. Conduct a “Frequent inspection” as described next.

**After the first use, the crane end-user/owner must conduct the following 2 types of inspection:**

2. **Frequent inspection** [29 CFR 1910.179(j)(1)(ii)(a)] — Daily to monthly intervals.

The following items shall be inspected for defects at the intervals specifically indicated, including observation *during operation* for any defects which might appear between inspections. All deficiencies such as those listed shall be carefully examined to determine whether they constitute a safety hazard:

- **[Inspect daily]** All functional operating mechanisms (mast, beam, socket, bearings, tie rod, rollers, and mast clamp) for maladjustment interfering with proper operation. Verify that the rollers operate smoothly by turning the crane 4-6 feet in one direction.
- **[Inspect daily (visually); inspect monthly and make a certification record, which includes the date of inspection, the signature of the person who performed the inspection and the serial number (or other identifier) of the hook inspected]** Hooks with deformation or cracks. Immediately discard hooks with cracks or that have a throat opening that is more than 15 percent in excess of normal throat opening, or that are twisted more than 10° from the plane of the unbent hook.
- **[Inspect daily (visually); monthly inspection with a certification record which includes the date of inspection, the signature of the person who performed the inspection and an identifier of the chain which was inspected]** Hoist chains, including end connections, for excessive wear, twist, distorted links interfering with proper function, or stretch beyond hoist manufacturer's recommendations.
- **[Inspect weekly]** All functional operating mechanisms (mast, beam, socket, tie rod, rollers, mast clamp, pins, and yokes, bolts and nuts, including anchor bolts and nuts) for excessive wear.
- **[Inspect weekly]** Rope reeving for noncompliance with hoist manufacturer's recommendations.

3. **Periodic inspection** [29 CFR 1910.179(j)(1)(ii)(b)] — 1 to 12-month intervals.

Complete inspections of the crane shall be performed at intervals depending upon its activity, severity of service, and environment, or as specifically indicated below. Perform all of the requirements described for frequent inspections and the following bulleted items. Carefully examine the crane for any problems such as those listed below to determine whether they constitute a safety hazard:

- Deformed, cracked, or corroded members.
- Loose bolts or rivets.
- Cracked or worn sheaves and drums.
- Worn, cracked or distorted parts such as pins, bearings, rollers, locking and clamping devices.
- Excessive wear on brake system parts, linings, pawls, and ratchets.
- Load, wind, and other indicators over their full range, for any significant inaccuracies.
- Gasoline, diesel, electric, or other power plants for improper performance or noncompliance with applicable safety requirements.
- Excessive wear of chain drive sprockets and excessive chain stretch.

**Cranes not in regular use:** for each of the 3 bullet points below, in addition to the *crane* inspection all rope which has been idle for a period of a month or more due to shutdown or storage of a crane on which it is installed must be given a thorough inspection before it is used. An appointed person, whose approval is required before the rope may be used, must inspect the rope for all types of deterioration. A certification record must be available for inspection. The record must include at least the date of inspection, the signature of the person who performed the inspection and an identifier for the rope inspected.

- A crane which has been idle for a period of 1 month or more, but less than 6 months, shall undergo a “Frequent inspection” before being returned to service.
- A crane which has been idle for a period of over 6 months shall be given a “Complete inspection” before placing in service.
- Standby cranes shall be given a “Frequent inspection” at least semi-annually (twice per year; 1 inspection each 6 months).

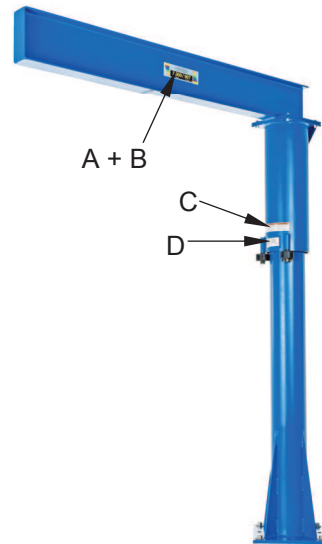
**Maintenance:**

At least once per month:

1. Check the mounting plate (base of the mast), the anchoring hardware, and the concrete foundation, particularly around the anchor bolts. Make sure that the mast is securely anchored (i.e. does not wobble). Confirm that anchoring hardware is in normal condition.
2. Examine the socket and the rollers attached to it. Confirm that both spring pins are securely in place. Each roller must be evenly worn and undamaged. The socket itself should be rigid and undamaged.
3. Test the function of the bearing. Rotate the boom from side to side. Lubricate the bearing whenever the boom becomes noisy while rotating or when its resistance to rotation increases. Replace a bearing if it is substantially worn.
4. Check the boom and its mounting bracket for structural damage, i.e. severe wear, bending, cracking, etc. Replace the entire boom assembly if structural damage is present.
5. Apply touch-up paint wherever the finish has been affected.

**Labeling diagram:**

Only use the crane if it is labeled as diagrammed below. ALL labels must be readable and undamaged. Replace all damaged/unreadable labels.



A: Label 391 (both sides of jib) – Capacity



B: Label 560, 561, or 562 (both sides of jib; applied to black rectangle of label 391)



C: Label 586 (on other side of jib) – Hazards of use

⚠ WARNING	⚠ ADVERTENCIA	⚠ AVERTISSEMENT
<ul style="list-style-type: none"> <li>• DO NOT exceed rated capacity</li> <li>• LOWER LOAD before moving to avoid load swing</li> <li>• NEVER STAND under, beside or in front of load</li> <li>• USE on hard level surface</li> <li>• INSPECT connections before using</li> <li>• READ manual before use</li> </ul>	<ul style="list-style-type: none"> <li>• No exceda la capacidad tasada</li> <li>• Descienda la carga antes de mover para evitar que la carga se balancee</li> <li>• Nunca se situe debajo, al lado o delante de la carga</li> <li>• Use en una superficie a nivel dura</li> <li>• Inspeccione las conexiones antes del uso</li> <li>• Lea el manual antes del uso</li> </ul>	<ul style="list-style-type: none"> <li>• NE PAS DÉPASSER la capacité nominale</li> <li>• DESCENDRE la charge avant de la transporter pour éviter la giration</li> <li>• JAMAIS vous mettre sous, à côté de ou devant une charge</li> <li>• UTILISER sur un sol plat et dur</li> <li>• INSPECTER les connexions avant utilisation</li> <li>• LIRE le guide avant utilisation</li> </ul>

D: Label 287 – Product data label.

MODEL/MODÉLO/MODÈLE _____
STATIC CAPACITY (evenly distributed) _____ lbs.
LA CAPACIDAD CONSTANTE (distribuida uniformemente) _____ kgs.
CAPACITÉ STATIQUE (distribuée régulièrement) _____ kgs.
SERIAL/SERIE/SÉRIE _____

287 REV 0812

## LIMITED WARRANTY

Vestil Manufacturing Corporation (“Vestil”) warrants product to be free of defects in material and workmanship during the warranty period. *Our warranty obligation is to provide a replacement for a defective original part if the part is covered by the warranty, after we receive a proper request from the warrantee (you) for warranty service.*

### Who may request service?

Only a warrantee may request service. *You are a warrantee if* you purchased the product from Vestil or from an authorized distributor AND Vestil has been fully paid.

### What is an “original part”?

An original part is a part used to make the product as shipped to the warrantee.

### What is a “proper request”?

A request for warranty service is proper if Vestil receives: 1) a photocopy of the Customer Invoice that displays the shipping date; AND 2) a written request for warranty service including your name and phone number. Send requests by any of the following methods:

<u>Mail</u>	<u>Fax</u>	<u>Email</u>
Vestil Manufacturing Corporation 2999 North Wayne Street, PO Box 507 Angola, IN 46703	(260) 665-1339 <u>Phone</u> (260) 665-7586	sales@vestil.com

In the written request, list the parts believed to be defective and include the address where replacements should be delivered.

### What is covered under the warranty?

After Vestil receives your request for warranty service, an authorized representative will contact you to determine whether your claim is covered by the warranty. Before providing warranty service, Vestil may require you to send the entire product, or just the defective part or parts, to its facility in Angola, IN. The warranty covers defects in the following original dynamic components: motors, hydraulic pumps, electronic controllers, switches and cylinders. It also covers defects in original parts that wear under normal usage conditions (“wearing parts”), such as bearings, hoses, wheels, seals, brushes, and batteries.

### How long is the warranty period?

The warranty period for original dynamic components is 90 days. For wearing parts, the warranty period is 90 days. The warranty periods begin on the date when Vestil ships the product to the warrantee. If the product was purchased from an authorized distributor, the periods begin when the distributor ships the product. Vestil may, at its sole discretion, extend the warranty periods for products shipped from authorized distributors by up to 30 days to account for shipping time.

### If a defective part is covered by the warranty, what will Vestil do to correct the problem?

Vestil will provide an appropriate replacement for any covered part. An authorized representative of Vestil will contact you to discuss your claim.

### What is not covered by the warranty?

1. Labor;
2. Freight;
3. Occurrence of any of the following, which automatically voids the warranty:
  - Product misuse;
  - Negligent operation or repair;
  - Corrosion or use in corrosive conditions;
  - Inadequate or improper maintenance;
  - Damage sustained during shipping;
  - Accidents involving the product;
  - Unauthorized modifications: DO NOT modify the product IN ANY WAY without first receiving written authorization from Vestil. Modification(s) might make the product unsafe to use or might cause excessive and/or abnormal wear.

### Do any other warranties apply to the product?

Vestil Manufacturing Corp. makes no other express warranties. All implied warranties are disclaimed to the extent allowed by law. Any implied warranty not disclaimed is limited in scope to the terms of this Limited Warranty.

