

Classic Mailbox Posts- 4890 Series

Mailbox Installation Instructions

U.S.P.S. APPROVED

Installing Mailboxes on a Classic Mailbox Post

Thank you for selecting Salsbury's classic mailbox post.

This instruction sheet is for installing a mailbox on a Salsbury classic mailbox post. Other installation instructions are available for mounting a newspaper holder, assembling the post, and mounting the post in a concrete footing.

When you install a curbside or roadside mailbox, make sure that it is easily accessible to the mail carrier. By regulation it should be 41" to 45" from the ground or street surface up to the inside floor of the mailbox. The door should be set back 6" to 8" back from the front face of the curb or the road edge. However, you should check with your local postmaster to ensure that the mailbox is installed according to local regulations.

4890 Classic Mailbox Post

All hardware to install the mailbox to the classic mailbox post is provided with the post. To install the mailbox, set the mailbox on the classic mailbox post, open the front door of the mailbox and install four (4) M8 x 1.25 x 20 mm long pan head bolts through the four (4) square holes in the inside floor of the mailbox and through the four (4) tapped holes on the top of the classic mailbox post. Installation is now complete. Additional hardware provided is not needed and may be discarded.

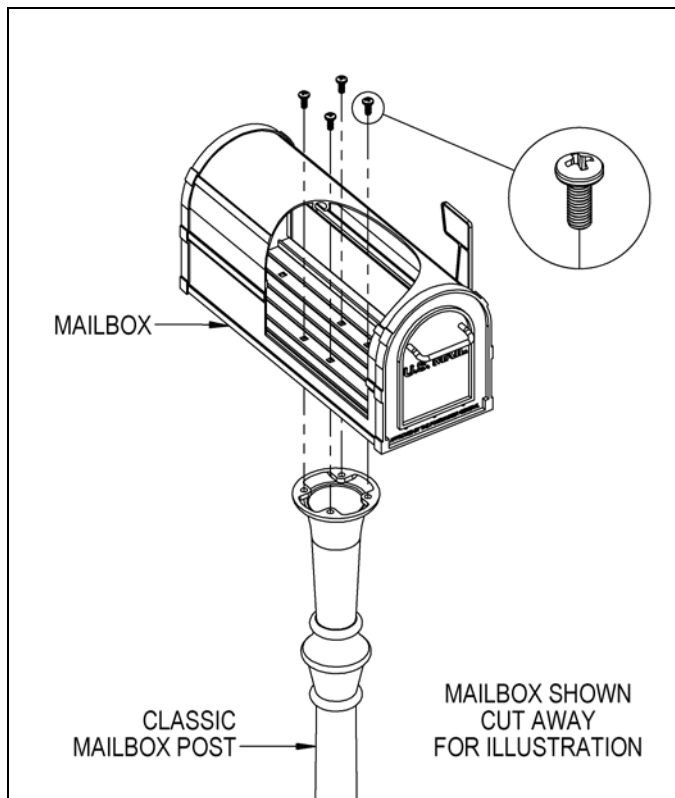

4891 Classic Mailbox Post

All hardware to install the mailbox to the one-sided classic mailbox post is included with the mounting arm. To attach the mailbox, open the front door of the mailbox and install four (4) 5/16"-18 x 1-3/4" long carriage bolts through the four (4) square holes in the inside floor of the mailbox, through four (4) 5/8" nylon spacers (thread onto bolt), and through the corresponding holes in top of the mounting arm. Install 5/16" flat washers and 5/16"-18 hex nuts on the ends of the four (4) bolts protruding below the bottom of the mounting arm. Installation is now complete. Additional hardware provided is not needed and may be discarded.

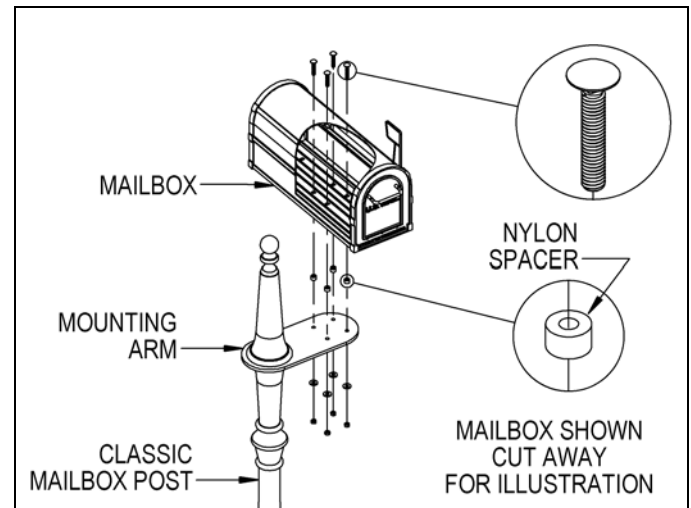

4892 Classic Mailbox Post

To install mailboxes to the 2-sided classic post, follow the instructions for the "4891 Classic Mailbox Post" and attach an additional mailbox to the mounting arm.

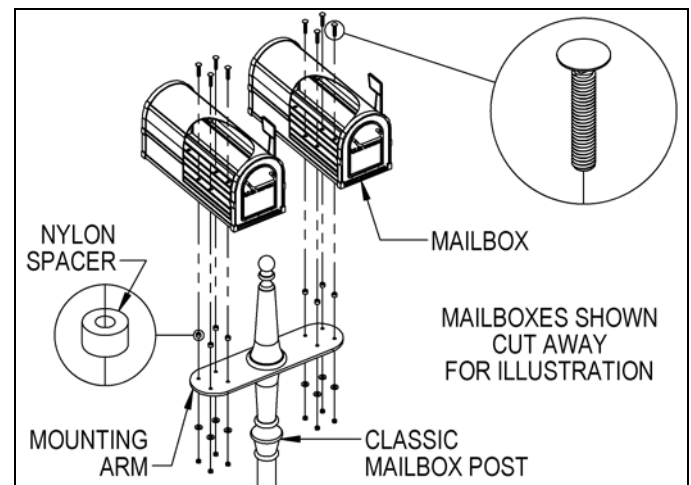

SALSBURY INDUSTRIES

1010 East 62nd Street, Los Angeles, CA 90001-1598
Phone: 1-800-624-5269 Int'l Phone: 323-846-6700
Fax: 1-800-624-5299 Int'l Fax: 323-846-6800

Classic Mailbox Post - 4890

Newspaper Holder Installation Instructions

U.S.P.S. APPROVED

Installing Newspaper Holder on 4890 Classic Mailbox Post

Thank you for selecting Salsbury Industries classic mailbox post.

This instruction sheet is for installing the mailbox on a 4890 Salsbury classic mailbox post with a newspaper holder. Other installation instructions are available for installing the mailbox on a 4891 or 4892 classic mailbox post, assembling the post, and mounting the post in a concrete footing.

When you install a curbside or roadside mailbox, make sure that it is easily accessible to the mail carrier. By regulation it should be 41" to 45" from the ground or street surface up to the inside floor of the mailbox. The door should be set back 6" to 8" from the front face of the curb or the road edge. However, you should check with your local postmaster to ensure that the mailbox is installed according to local regulations.

Newspaper Holder Installation to 4890 Classic Post

All hardware required to assemble the newspaper holder to the classic mailbox post is provided with the post. To attach a newspaper holder to the post, install four (4) M8 x 1.25 x 20 mm long pan head bolts through the four (4) square holes shown in the inside floor of the newspaper holder and through the four (4) tapped holes on the top of the classic mailbox post. Insert a Phillips head screw driver through each square hole directly above, and in the top of the newspaper holder, to tighten the pan head bolts.

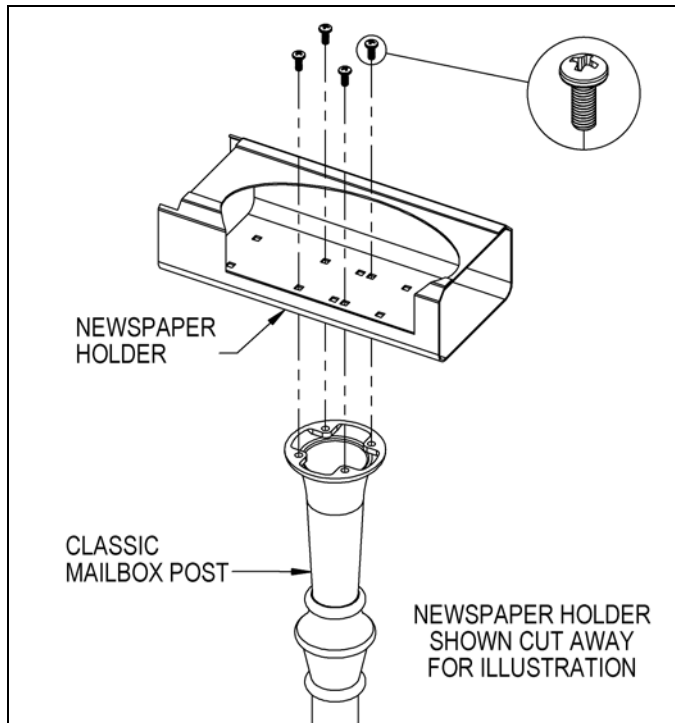

Mailbox Installation to Newspaper Holder

All hardware to attach the mailbox to the newspaper holder is included with the newspaper holder. To attach a mailbox to a newspaper holder, open the front door of the mailbox and install four (4) 5/16"-18 X 3/4" long carriage bolts into (4) square holes in the floor of the mailbox and through the four (4) square holes shown on the top of the newspaper holder. Install 5/16" flat washers and 5/16"-18 hex nuts on the ends of the four (4) bolts protruding below the top of the newspaper holder. Cover the hex nuts with cap plugs. Installation is now complete. Additional hardware provided is not needed and may be discarded.

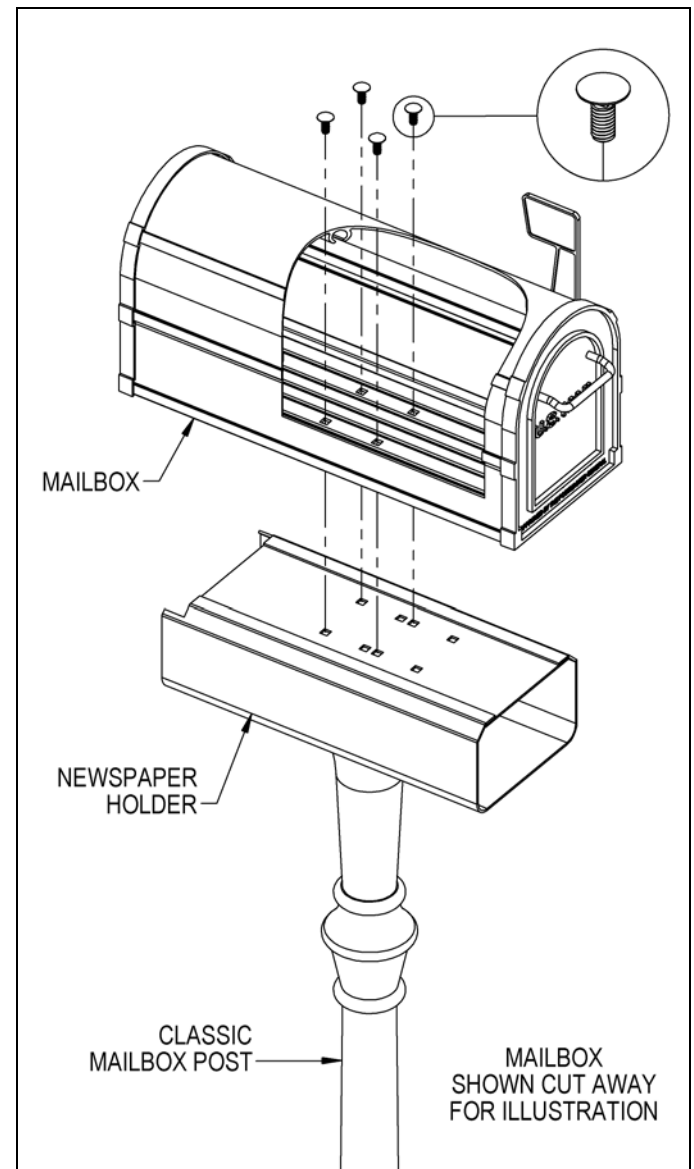

SALSBURY INDUSTRIES

1010 East 62nd Street, Los Angeles, CA 90001-1598
Phone: 1-800-624-5269 Int'l Phone: 323-846-6700
Fax: 1-800-624-5299 Int'l Fax: 323-846-6800

Classic Mailbox Post – 4891, 4892

Newspaper Holders Installation Instructions

U.S.P.S. APPROVED

Installing Newspaper Holders on Classic Mailbox Posts

Thank you for selecting Salsbury Industries classic mailbox post.

This instruction sheet is for installing the mailbox(es) on a Salsbury 4891 or 4892 classic mailbox post with a newspaper holder(s). Other installation instructions are available for installing the mailbox on a 4890 classic mailbox post, assembling the post, and mounting the post in a concrete footing.

When you install a curbside or roadside mailbox, make sure that it is easily accessible to the mail carrier. By regulation it should be 41" to 45" from the ground or street surface up to the inside floor of the mailbox. The door should be set back 6" to 8" from the front face of the curb or the road edge. However, you should check with your local postmaster to ensure that the mailbox is installed according to local regulations.

Newspaper Holder Installation to Classic Post

Installation of newspaper holders to each classic mailbox post, 4891 one-sided, or 4892 two-sided, is the same. Attach one newspaper holder to the 4891 one-sided post. Attach one additional newspaper holder to the 4892 two-sided post. All hardware required to assemble the newspaper holders(s) to the classic mailbox post is included with the mounting arm. To attach a newspaper holder to the post, install four (4) 5/16"-18 x 1-3/4" long carriage bolts through the four (4) square holes shown in the inside floor of the newspaper holder and through the corresponding holes in top of the mounting arm. Install 5/16" flat washers and 5/16"-18 hex nuts on the ends of the four (4) bolts protruding below the bottom of the mounting arm. Repeat these steps for the other newspaper holder.

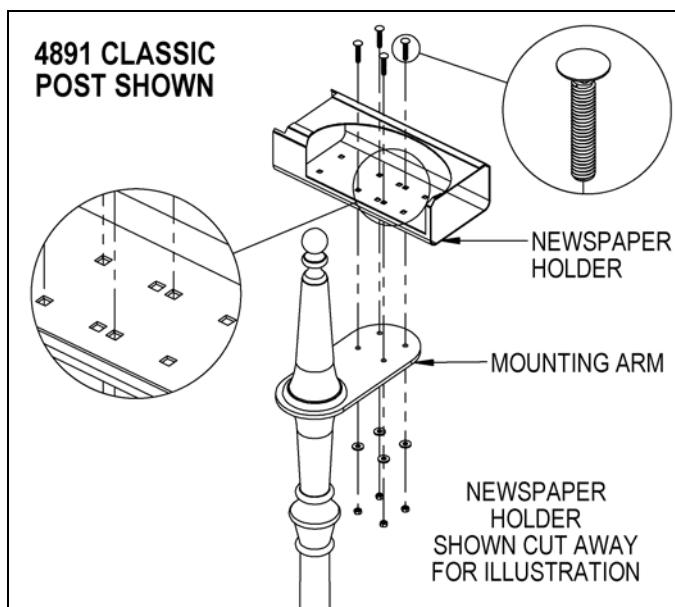

Mailbox Installation to Newspaper Holders

Installation of the mailbox to the newspaper holder on each classic mailbox post, 4891 one-sided, or 4892 two-sided, is the same. Attach one mailbox to the 4891 one-sided post. Attach one additional mailbox to the 4892 two-sided post. All hardware to attach the mailbox(es) to the newspaper holder(s) is included with the newspaper holder(s). To attach a mailbox to a newspaper holder, open the front door of the mailbox and install four (4) 5/16"-18 X 3/4" long carriage bolts into (4) square holes in the floor of the mailbox and through the four (4) square holes shown on the top of the newspaper holder. Install 5/16" flat washers and 5/16"-18 hex nuts on the ends of the four (4) bolts protruding below the top of the newspaper holder. Cover the hex nuts with cap plugs. Repeat these steps for the other mailbox. Installation is now complete. Additional hardware provided is not needed and may be discarded.

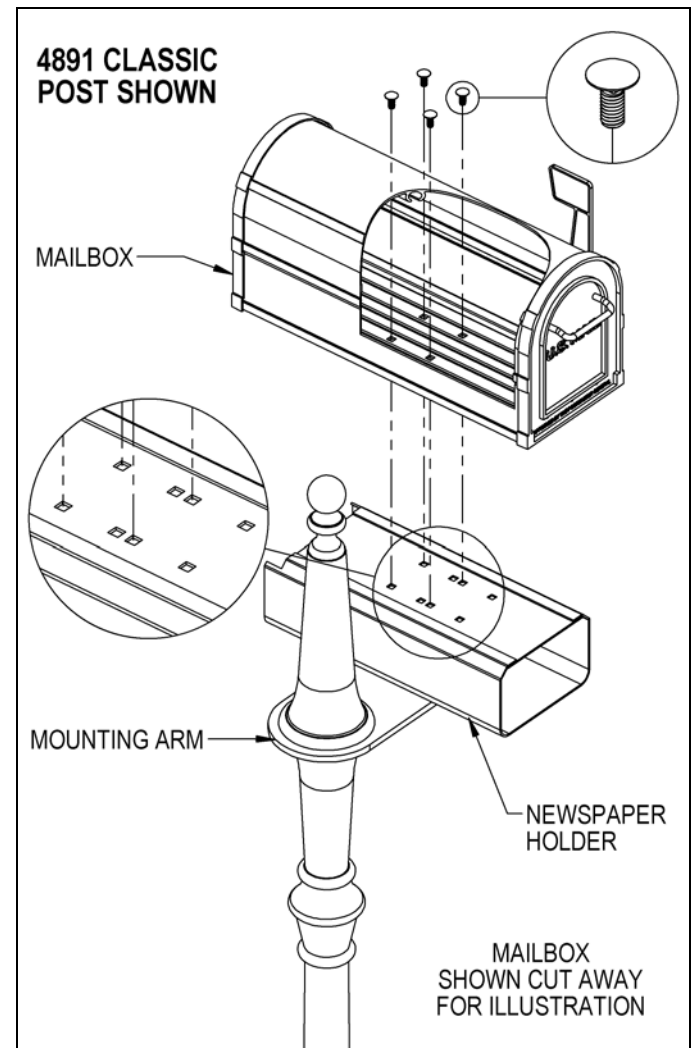

SALSBURY INDUSTRIES

1010 East 62nd Street, Los Angeles, CA 90001-1598
Phone: 1-800-624-5269 Int'l Phone: 323-846-6700
Fax: 1-800-624-5299 Int'l Fax: 323-846-6800

CLASSIC MAILBOX POSTS

Post Assembly Installation Instructions

U.S.P.S. APPROVED

Classic Mailbox Post Assembly

Thank you for selecting Salsbury's classic mailbox post. This instruction sheet is for assembling the top mounted, 1-sided (1- mailbox per side), or 2-sided (2 mailboxes per side) classic mailbox post. Other installation instructions are available for installing the mailbox, mounting a newspaper holder, and mounting the post in a concrete footing. All hardware to assemble the classic mailbox post is provided.

4890 – Top Mounted

Attach the base to the post by installing two (2) M8 x 1.25 x 25 mm long hex bolts through two (2) M8 flat washers then through the base and through the two (2) tapped holes on the bottom of the base. Installation is now complete.

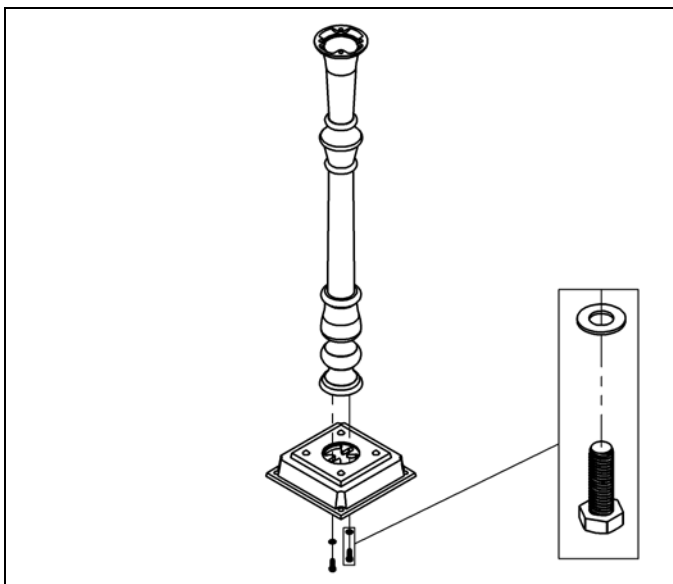

4891 – 1 Sided for 1 Mailbox

1. Attach the base to the post by following the step described for the 4890 top mounted classic post.

2. Install the M12 x 1.75 x 40 mm long hex bolt through the center hole on the mounting arm and through the M12 x 1.75 hex nut.

3. Attach the mounting arm to the post by installing four (4) M8 x 1.25 x 20 mm long pan head bolts through the four (4) holes on the top of the mounting arm and through the four (4) tapped holes on the top of the classic mailbox post.

4. Install the finial onto the M12 x 1.75 x 40 mm long hex bolt. Installation is now complete.

Note: On the 4891 classic mailbox post, the mounting arm which accommodates the mailbox can be on either the left or right side. When attaching the post to the ground, position the post so the mounting arm is on the side desired. Then mount the mailbox on the mounting arm with the mailbox facing the street or roadway.

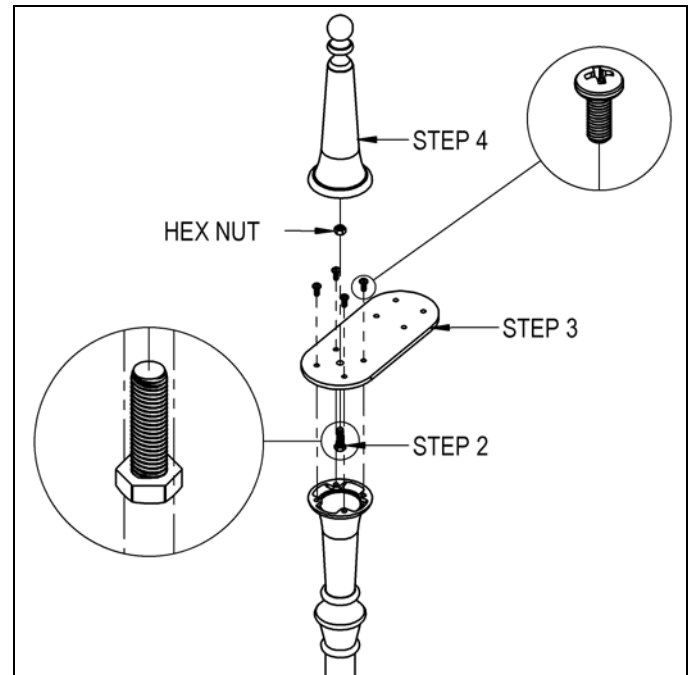

4892 – 2 Sided for 2 Mailboxes

To assemble the 4892 classic mailbox post, follow the steps listed for the 4891 classic mailbox post.

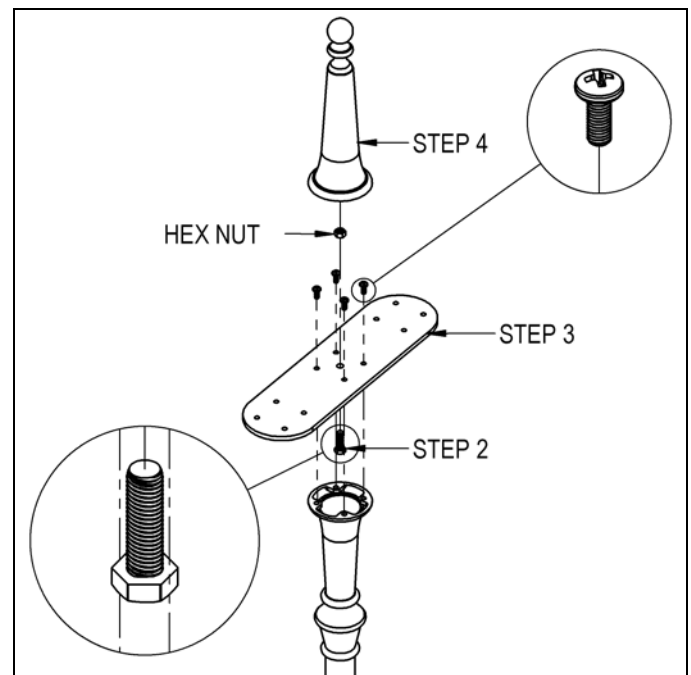

SALSBURY INDUSTRIES

1010 East 62nd Street, Los Angeles, CA 90001-1598
Phone: 1-800-624-5269 Int'l Phone: 323-846-6700
Fax: 1-800-624-5299 Int'l Fax: 323-846-6800

Classic Mailbox Post

4896 In-Ground Mounting Kit Installation Instructions

U.S.P.S. APPROVED

Installing the In-Ground Mounting Kit

Thank you for selecting Salsbury's in-ground mounting kit.

This instruction sheet is for installing the in-ground mounting kit into a concrete footing and installing a classic mailbox post onto the in-ground mounting kit. Other installation instructions are available for assembling the post, installing the mailbox, and mounting a newspaper holder. All hardware to assemble the classic mailbox post to the in-ground mounting kit is provided with the mounting kit.

When you install a curbside or rural mailbox, make sure that it is easily accessible to the mail carrier. By regulation it should be 41" to 45" from the ground or street surface up to the inside floor of the mailbox. The door should be set back 6" to 8" back from the front face of the curb or the road edge. However, you should check with your local postmaster to ensure that the mailbox is installed according to local regulations.

To install the in-ground mounted kit, begin by digging a hole for the concrete footing and then prepare the concrete. The top surface of the footing should be about 15" by 15". The concrete should extend into the ground 24" or greater if your local frost line is deeper. Installing the concrete below the frost line will prevent movement during ground freezing and thawing. The bottom of the hole for the concrete footing should be filled with a depth of about 6" of gravel to promote drainage under the post. The top of the footing should be sloped for water runoff.

When digging the hole for the footing, be careful to not puncture water, sewer, or gas lines.

After digging the hole, fill the hole with the prepared concrete mix to within two inches of where the top plate of the in-ground mounting kit will be positioned. Prod the mix with a stick while filling to reduce any air pockets. Set the post of the in-ground mounting kit centered into the concrete. Use a carpenter's level on the top plate of the in-ground mounting kit to ensure that it is level. Periodically check the level as the concrete is curing. Fill the top of the concrete with soil after it has cured.

To install the classic mailbox post to the in-ground mounting kit, install four (4) 3/8" - 16 x 1.75" long hex bolts through the base of post and through the four (4) tapped holes on the top plate of the in-ground mounting kit. Cover the hex nuts with cap plugs. Installation is now complete.

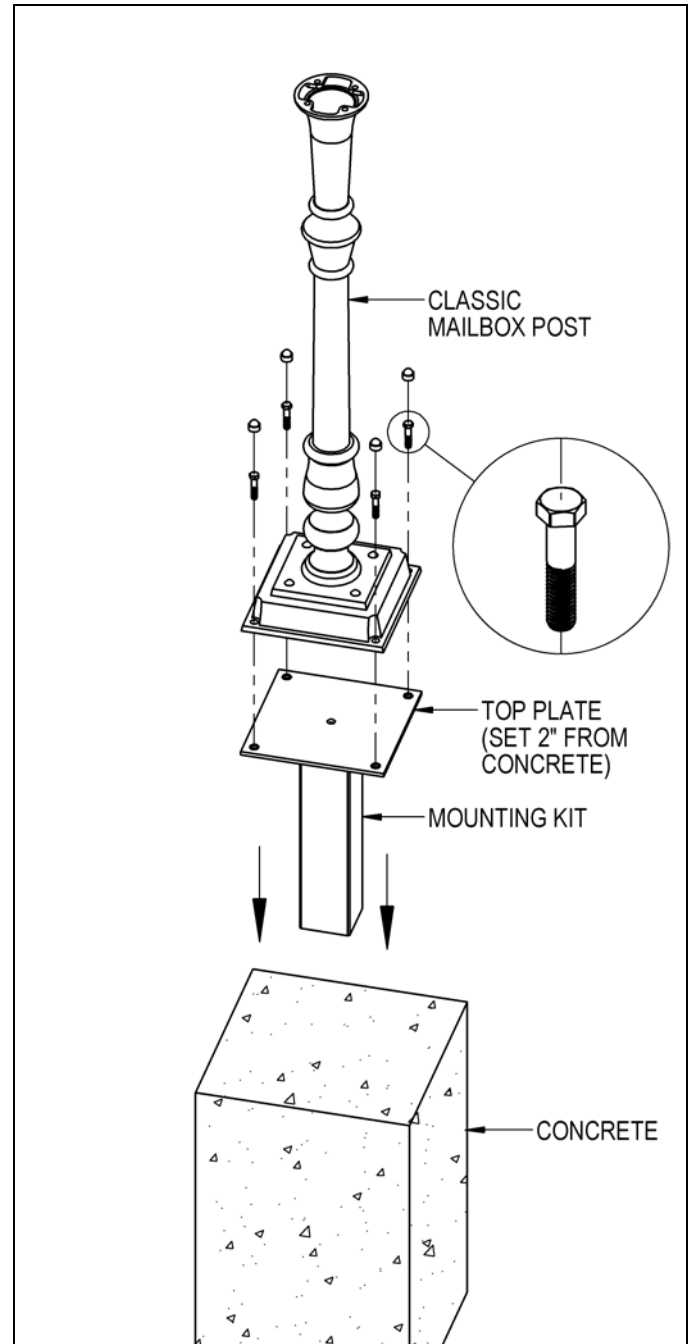

SALSBURY INDUSTRIES

1010 East 62nd Street, Los Angeles, CA 90001-1598
Phone: 1-800-624-5269 Int'l Phone: 323-846-6700
Fax: 1-800-624-5299 Int'l Fax: 323-846-6800

Classic Mailbox Post

Bolt Mounted Post Installation Instructions

U.S.P.S. APPROVED

Installing the Bolt Mounted Classic Mailbox Post

Thank you for selecting Salsbury's classic mailbox post.

This instruction sheet is for installing the classic mailbox post into a concrete footing. Other installation instructions are available for assembling the post, installing the mailbox, and mounting a newspaper holder. All hardware to install the post into the footing is provided with the post.

When you install a curbside or rural mailbox, make sure that it is easily accessible to the mail carrier. By regulation it should be 41" to 45" from the ground or street surface up to the inside floor of the mailbox. The door should be set back 6" to 8" back from the front face of the curb or the road edge. However, you should check with your local postmaster to ensure that the mailbox is installed according to local regulations.

To install the bolt mounted mailbox post, begin by digging a hole for the concrete footing and then prepare the concrete. The top surface of the footing should be about 15" by 15". The concrete should extend into the ground 24" or greater if your local frost line is deeper. Installing the concrete below the frost line will prevent movement during ground freezing and thawing. The bottom of the hole for the concrete footing should be filled with a depth of about 6" of gravel to promote drainage under the post. The top of the footing should be sloped for water runoff.

When digging the hole for the footing, be careful to not puncture water, sewer, or gas lines.

Place the four (4) M10 x 1.50 x 100 mm long hex bolts into the concrete in a 10" x 10" pattern protruding at least 1" above the concrete surface to align with the holes in the base of the post. The concrete footing should include reinforcing steel.

When the concrete has cured, attach the post to the footing by setting it over the four (4) hex bolts protruding from the footing. Secure the post with M10 x 1.50 hex nuts and M10 flat washers.

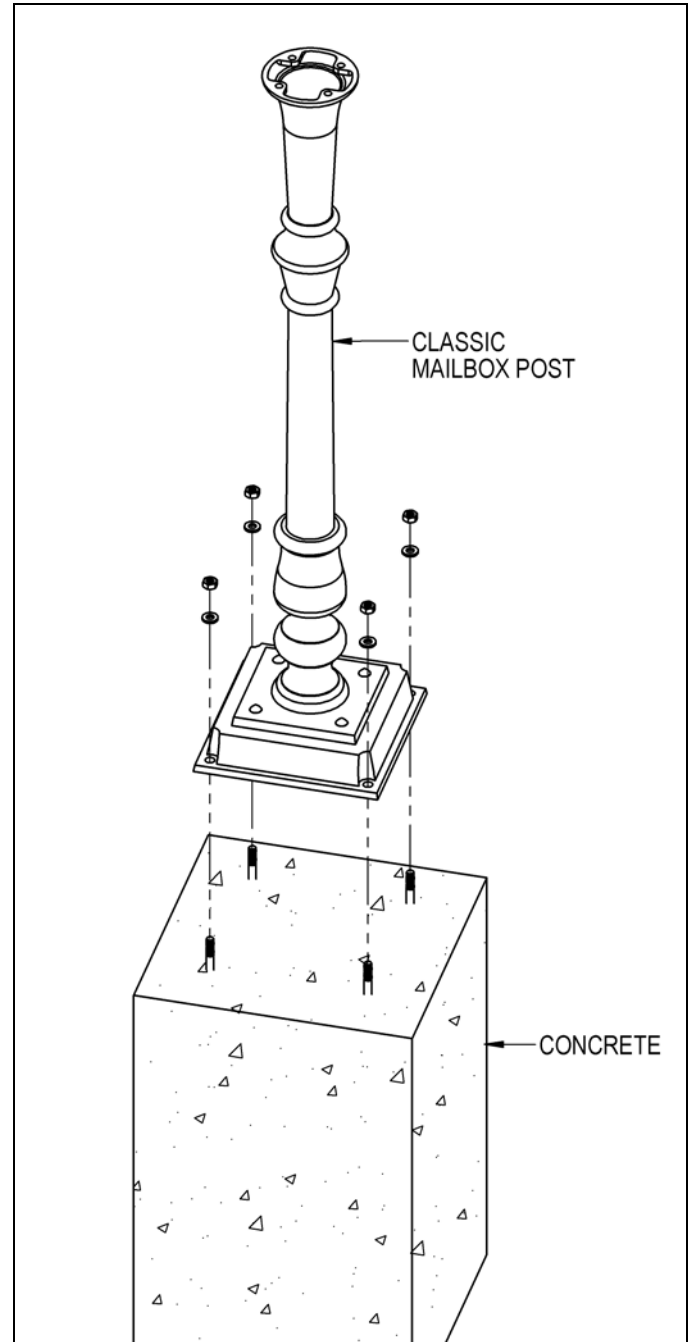

SALSBURY INDUSTRIES

1010 East 62nd Street, Los Angeles, CA 90001-1598
Phone: 1-800-624-5269 Int'l Phone: 323-846-6700
Fax: 1-800-624-5299 Int'l Fax: 323-846-6800