

NO.	DESCRIPTION	MATERIAL	FINISH	QTY
1	SLIP NUT	BRASS	CP	2
2	WASHER	RUBBER	BLACK	2
3	J BEND	BRASS	CP	1
4	WALL BEND	BRASS	CP	1
5	FLANGE	S.S.	PLAIN	1
6	1 1/2"x1 1/4" REDUCED WASHER	PLASTIC	PLAIN	1

SIZE	UNIT	PER CTMR DWG	DATE	REV.
A4	INCH			

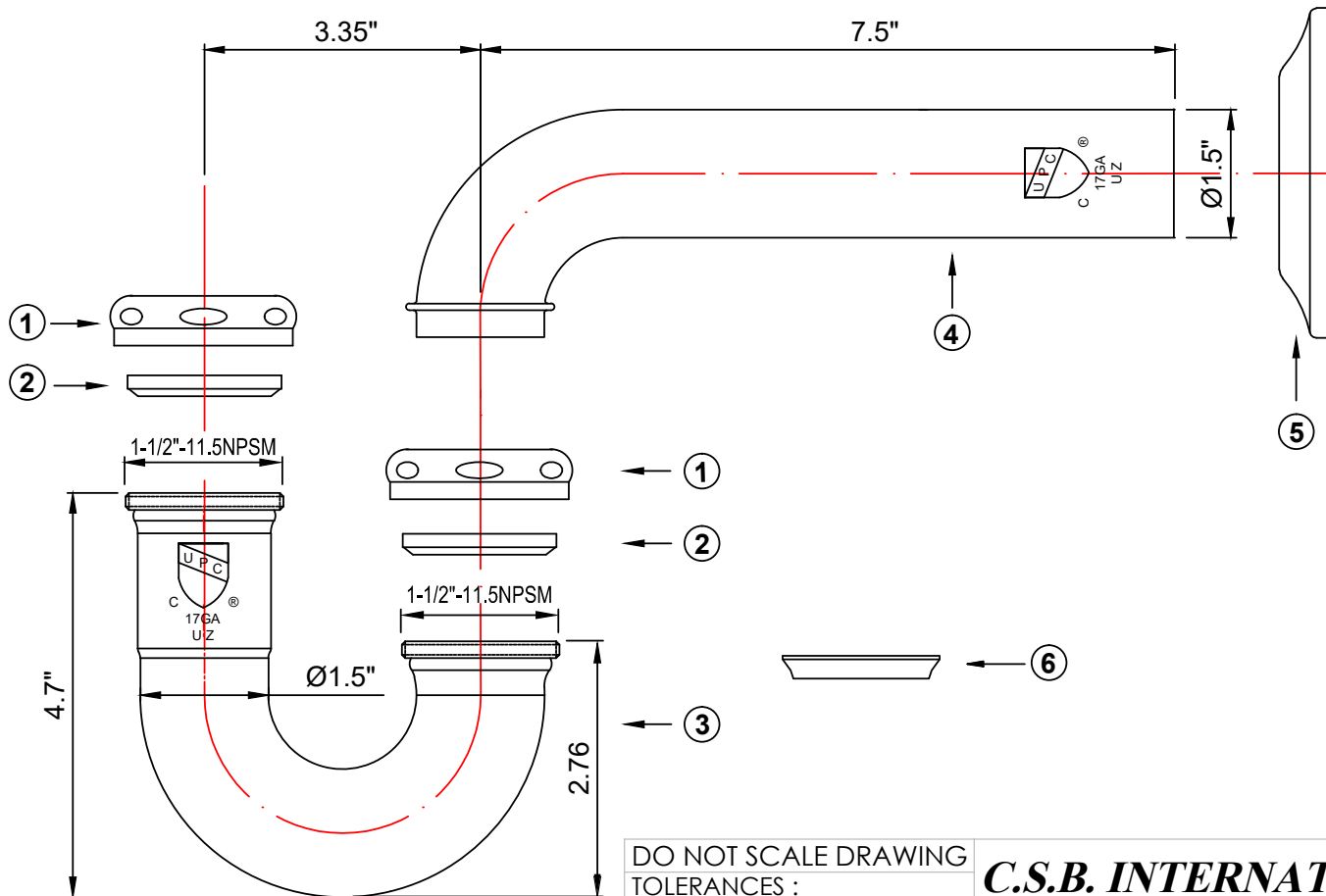

DO NOT SCALE DRAWING  
TOLERANCES :  
UNLESS OTHERWISE SPECIFIED  
.XX ± 0.010      ANGLE ± 1/2°  
.XXX ± 0.005      FRACTION ± 1/64  
W.T.:  
MATERIAL:      *SEE LIST*  
FINISH:          *SEE LIST*

**C.S.B. INTERNATIONAL PRODUCTS INC.**

TITLE *1 1/2 P-TRAP LESS CLEANOUT  
W/1 1/4 x 1 1/2 WASHER AND BRASS*

DRAWN      APR.

*Makey*      5/12/23

SCALE      PROJECTION

FREE     

SHEET:      FILE

ITEM NO.      REV.      A

*15BCPBAG*

1 / 1