

SPEAKMAN NEO™

Hand-held Shower VS-3010

SPECIFICATION

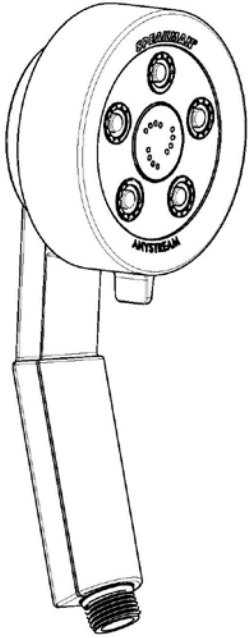

FEATURES:

- 50 adjustable spays
- Massage spray setting
- Modern design
- 360° spray adjusting faceplate
- 5' hose & arm bracket included

COMPLIANCE:

- Certified to ASME A112.18.1/CSA B125.1 standards
- WaterSense certified (E2)



AVAILABLE FINISHES:

ADD SUFFIX TO MODEL #

- Polished Chrome (standard)
- Brushed Nickel -BN
- Polished Nickel -PN

OPTIONS:

- 2.0 gpm (7.6 L/min) flow rate -E2

WARRANTY:

- 1 year limited

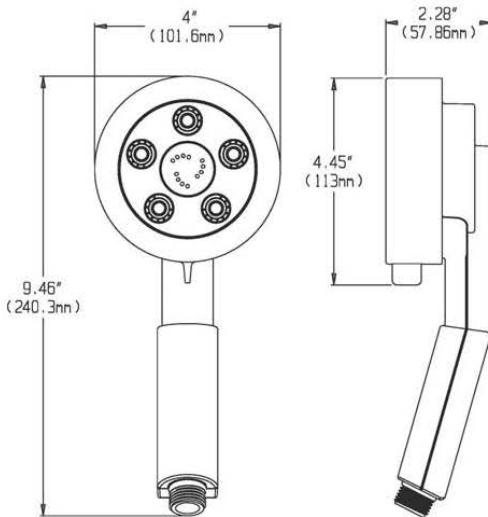

NOTE: 1. All dimensions are in inches (millimeters) unless otherwise specified and are subject to change without notice.

THIS SPACE FOR ARCHITECT/ENGINEER APPROVAL.

SPEAKMAN®

400 ANCHOR MILL ROAD | NEW CASTLE, DE 19720
P: 800-537-2107 | F: 800-977-2747
WWW.SPEAKMANCOMPANY.COM



REVISION DATE: JULY 2012