

# WasteAid®

FOOD WASTE DISPOSER

# PRO

# 459

1/3 HORSEPOWER



### Easy and Fast to Install

Speed Master Mounting System provides fast and economical installation.

### Corrosion Proof

Lifetime warranty against failure due to corrosion.

### Permanent Magnet Motor

Maximum torque instantly with the power to cut through potential jams.

### Removable Splash Guard

Removable splash guard, ideal for easy cleaning and replacement.

### Attached Power Cord

Ready to plug in.



### BIO SHIELD® Antimicrobial for ODOR PROTECTION!

Disposers are treated with an antimicrobial agent molded inside providing protection against odor causing bacteria growth.



### TORQUE MASTER®

**Balanced Grinding System:**  
A combination of computer designed and balanced components working in unison to provide superior torque grind speed and long system life.

|                                     |                                     |
|-------------------------------------|-------------------------------------|
| <b>HORSEPOWER</b>                   | 1/3 HP                              |
| <b>MOTOR SPEED RPM</b>              | 2400 RPM                            |
| <b>VOLTAGE</b>                      | 120v                                |
| <b>AMPS</b>                         | 4.5                                 |
| <b>CYCLES</b>                       | 60                                  |
| <b>BEARINGS</b>                     | Permanently Lubricated, Sleeve Type |
| <b>MOTOR TYPE</b>                   | Permanent Magnet                    |
| <b>SPLASH GUARD</b>                 | Removable                           |
| <b>GRIND RING</b>                   | Stainless Steel                     |
| <b>SWIVEL IMPELLERS</b>             | Stamped Stainless Steel             |
| <b>BALANCED TURNTABLE</b>           | Stainless Steel                     |
| <b>BALANCED ARMATURE SHAFT</b>      | Yes                                 |
| <b>HOPPER</b>                       | Corrosion Proof                     |
| <b>DRAIN HOUSING</b>                | Corrosion Proof                     |
| <b>APPLIANCE PROTECTOR</b>          | Manual Reset                        |
| <b>SINK FLANGE CAP</b>              | Stainless Steel                     |
| <b>MOUNT ASSEMBLY</b>               | Speed Master-Threaded               |
| <b>SOUND SHELL</b>                  | Partial                             |
| <b>ATTACHED POWER CORD</b>          | Yes                                 |
| <b>DISHWASHER CONNECTION</b>        | Yes                                 |
| <b>UNIT WEIGHT</b>                  | 9 lb                                |
| <b>INDIVIDUAL SHIPPING WEIGHT</b>   | 10 lb                               |
| <b>LIFETIME CORROSION GUARANTEE</b> | Yes                                 |
| <b>WARRANTY</b>                     | 2 Years                             |

### Dimensions

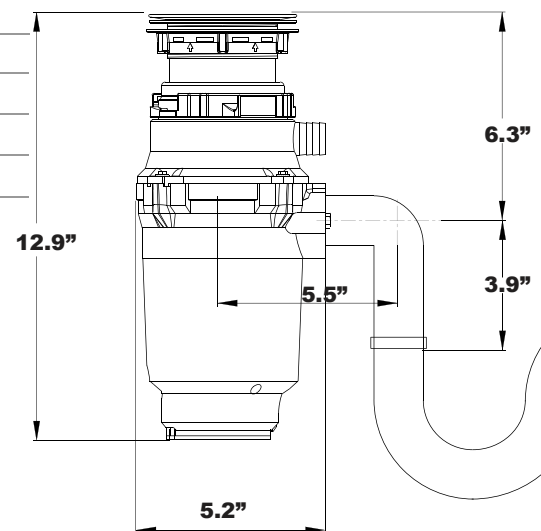

### Joneca Corporation

4332 E. La Palma Avenue, Anaheim, California 92807  
Telephone: 714.993.5997 Fax: 714.993.2126 Toll Free 1-888-8Joneca  
Website: [www.Joneca.com](http://www.Joneca.com) Email: [ContactUs@Joneca.com](mailto:ContactUs@Joneca.com)

©2017 Joneca Corporation, All Rights Reserved.

SS-459-181