

### PRESSURE TEMPERATURE CHART

TEMP. °F	R-12	R-134A	R-22	R-410A
-60	19.0	21.6	11.9	2.1
-55	17.3	20.1	9.2	3.4
-50	15.4	18.5	6.1	5.8
-45	13.3	16.7	2.7	8.6
-40	11.0	14.6	0.6	11.6
-35	8.3	12.3	2.6	14.9
-30	5.4	9.7	4.9	18.5
-25	2.3	6.7	7.4	22.5
-20	0.6	3.5	10.2	26.9
-15	2.5	0.1	13.2	31.7
-10	4.5	2.0	16.5	36.8
-5	6.8	4.2	20.1	42.5
0	9.2	6.5	24.0	48.6
5	11.8	9.2	28.2	55.2
10	14.7	12.0	32.8	62.3
15	17.7	15.1	37.7	70.0
20	21.1	18.5	43.1	78.3
25	24.6	22.2	48.8	87.3
30	28.5	26.1	54.9	96.8
35	32.6	30.4	61.5	107.1
40	37.0	35.1	68.5	118.0
45	41.7	40.1	76.0	129.7
50	46.7	45.5	84.0	142.2
55	52.1	51.2	92.6	155.5
60	57.7	57.4	101.6	169.6
65	63.8	64.1	111.2	184.6
70	70.2	71.1	121.4	200.6
75	7.0	78.7	132.2	217.4
80	84.2	86.7	143.6	235.3
85	91.8	95.3	155.7	254.1
90	99.8	104.3	168.4	274.1
95	108.2	114.0	181.8	295.1
100	117.2	124.2	195.9	317.2
105	126.5	135.0	210.7	340.5
110	136.4	146.4	226.3	365.0
115	146.8	158.4	242.7	390.7
120	157.6	171.2	259.9	417.7
125	169.0	184.6	277.9	445.9
130	181.0	198.7	296.8	475.6
135	193.5	213.6	316.5	506.5
140	206.6	229.2	337.2	539.0
145	220.3	245.6	358.8	572.8
150	234.6	262.9	381.4	608.1
155	249.5	281.1	405.1	645.0
160	265.1	300.0	429.8	

Shaded Area - Vacuum (in. Hg)  
 Non-Shaded Area - Vapor Pressure (PSIG)

### CHECKING SUBCOOLING FOR A/C & HEAT PUMPS

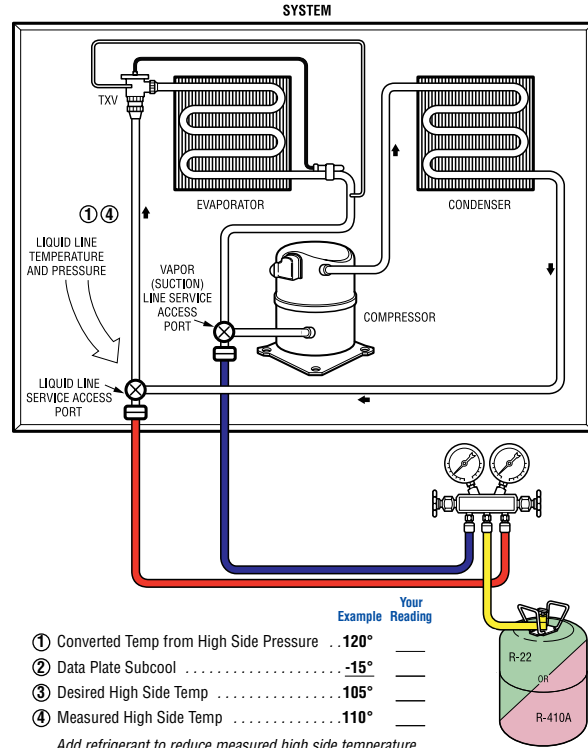

### CHECKING SUPERHEAT FOR A/C & HEAT PUMPS

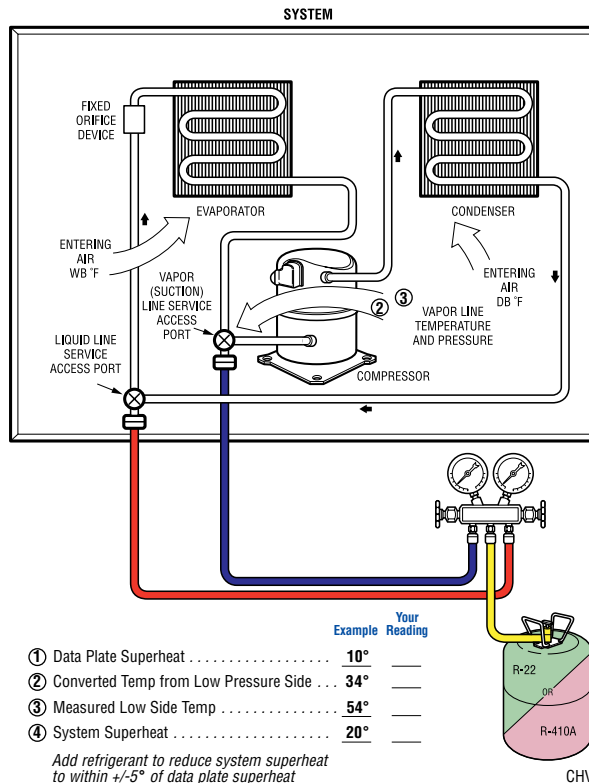

CHV025 - 10-19-11

Some items on this page may require additional delivery time. For more information please call 1-800-431-3000.